

<p>OPEN SOURCE HARDWARE LICENSE LGPL</p>		UNLESS OTHERWISE SPECIFIED:		NAME	DATE	<p>TITLE: Hinge Plate 2 Required 3/4" x 3-1/2" Pine</p>		
		DIMENSIONS ARE IN INCHES TOLERANCES: FRACTIONAL \pm ANGULAR: MACH \pm BEND \pm TWO PLACE DECIMAL \pm THREE PLACE DECIMAL \pm	DRAWN					
		INTERPRET GEOMETRIC TOLERANCING PER:	CHECKED					
		MATERIAL Material <not specified>	ENG APPR.					
	NEXT ASSY	USED ON	MFG APPR.			SIZE	DWG. NO.	REV
	APPLICATION	DO NOT SCALE DRAWING	Q.A.			reprap_Alt_stretch_test_sto		
			COMMENTS:			SCALE: 1:1	WEIGHT: 2.397	SHEET 1 OF 11

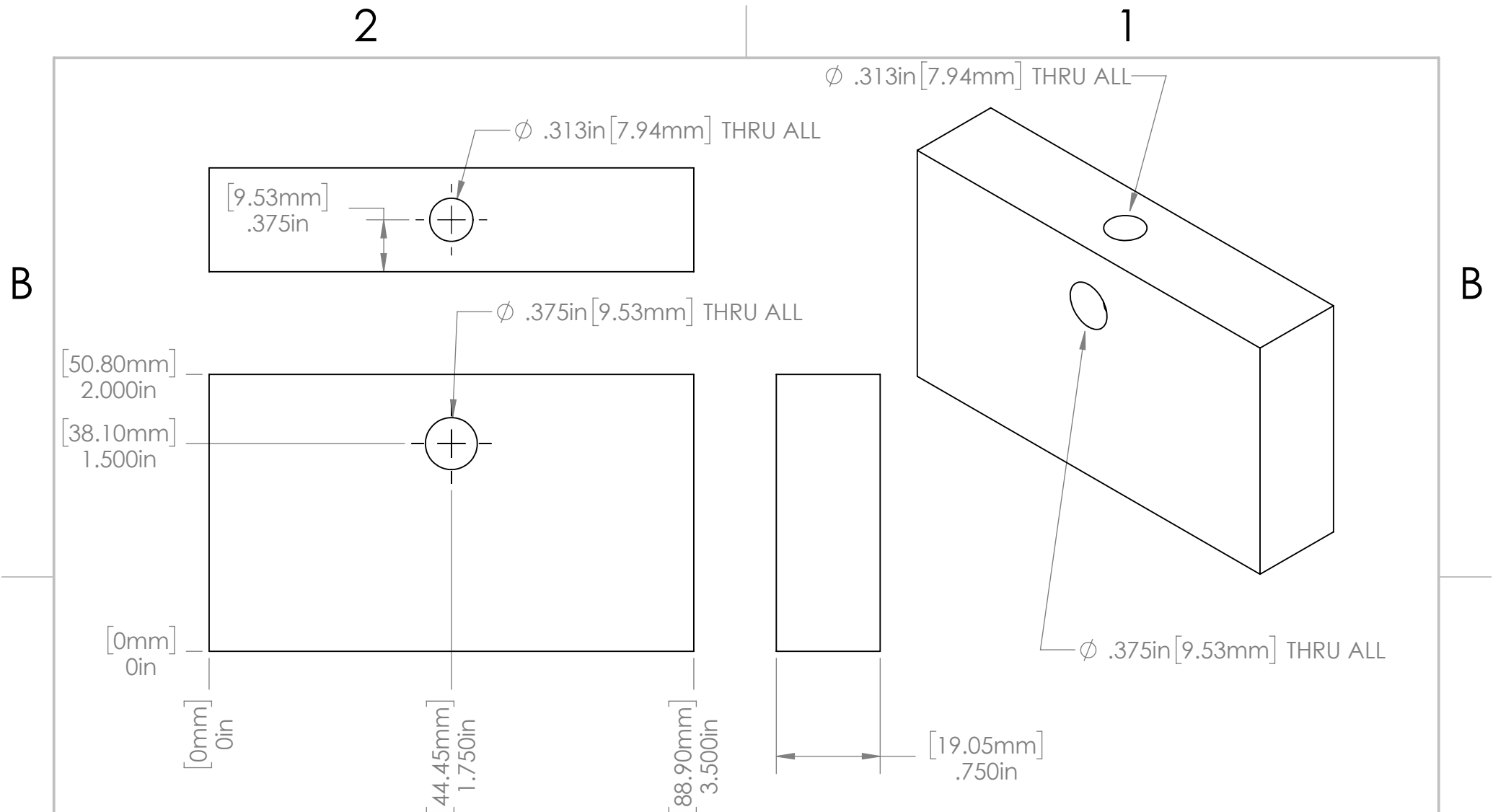

		UNLESS OTHERWISE SPECIFIED:		NAME	DATE	TITLE: Indicator Holder Block 1 Required 3/4" x 3-1/2" Pine	
		DIMENSIONS ARE IN INCHES TOLERANCES: FRACTIONAL \pm ANGULAR: MACH \pm BEND \pm TWO PLACE DECIMAL \pm THREE PLACE DECIMAL \pm		DRAWN			
OPEN SOURCE HARDWARE LICENSE LGPL		INTERPRET GEOMETRIC TOLERANCING PER:		CHECKED		SIZE DWG. NO. REV	
		MATERIAL Material <not specified>		ENG APPR.			
NEXT ASSY		USED ON	FINISH	MFG APPR.		reprap_1 Aelt_stretch_test_sto	
APPLICATION		DO NOT SCALE DRAWING		Q.A.			
				COMMENTS:		SCALE: 1:1 WEIGHT: 1.426 SHEET 2 OF 11	

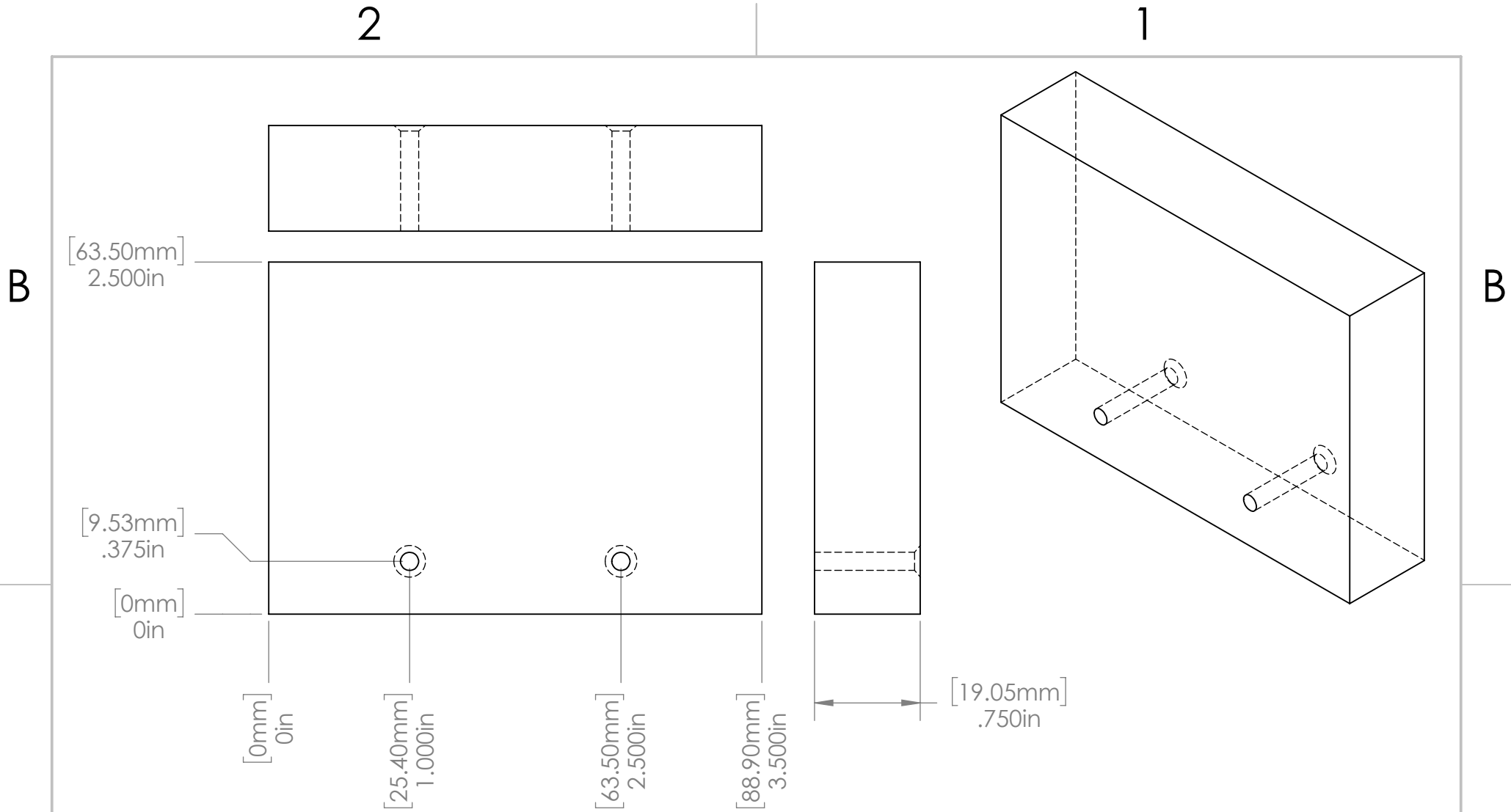

<p>OPEN SOURCE HARDWARE LICENSE LGPL</p>			UNLESS OTHERWISE SPECIFIED:		NAME	DATE	<p>TITLE: Frame Top Block 1 Required 3/4" x 3-1/2" Pine</p>
			DIMENSIONS ARE IN INCHES	DRAWN			
			TOLERANCES:	CHECKED			
			FRACTIONAL ±	ENG APPR.			
			ANGULAR: MACH ± BEND ±	MFG APPR.			
		TWO PLACE DECIMAL ±	Q.A.				
		THREE PLACE DECIMAL ±	COMMENTS:				
		INTERPRET GEOMETRIC TOLERANCING PER:					
		MATERIAL	Material <not specified>				
		FINISH					
	NEXT ASSY	USED ON					
	APPLICATION		DO NOT SCALE DRAWING				

SIZE	DWG. NO.	REV
SCALE: 1:1	WEIGHT: 1.851	SHEET 3 OF 11

reprap_1 A Belt stretch test sto

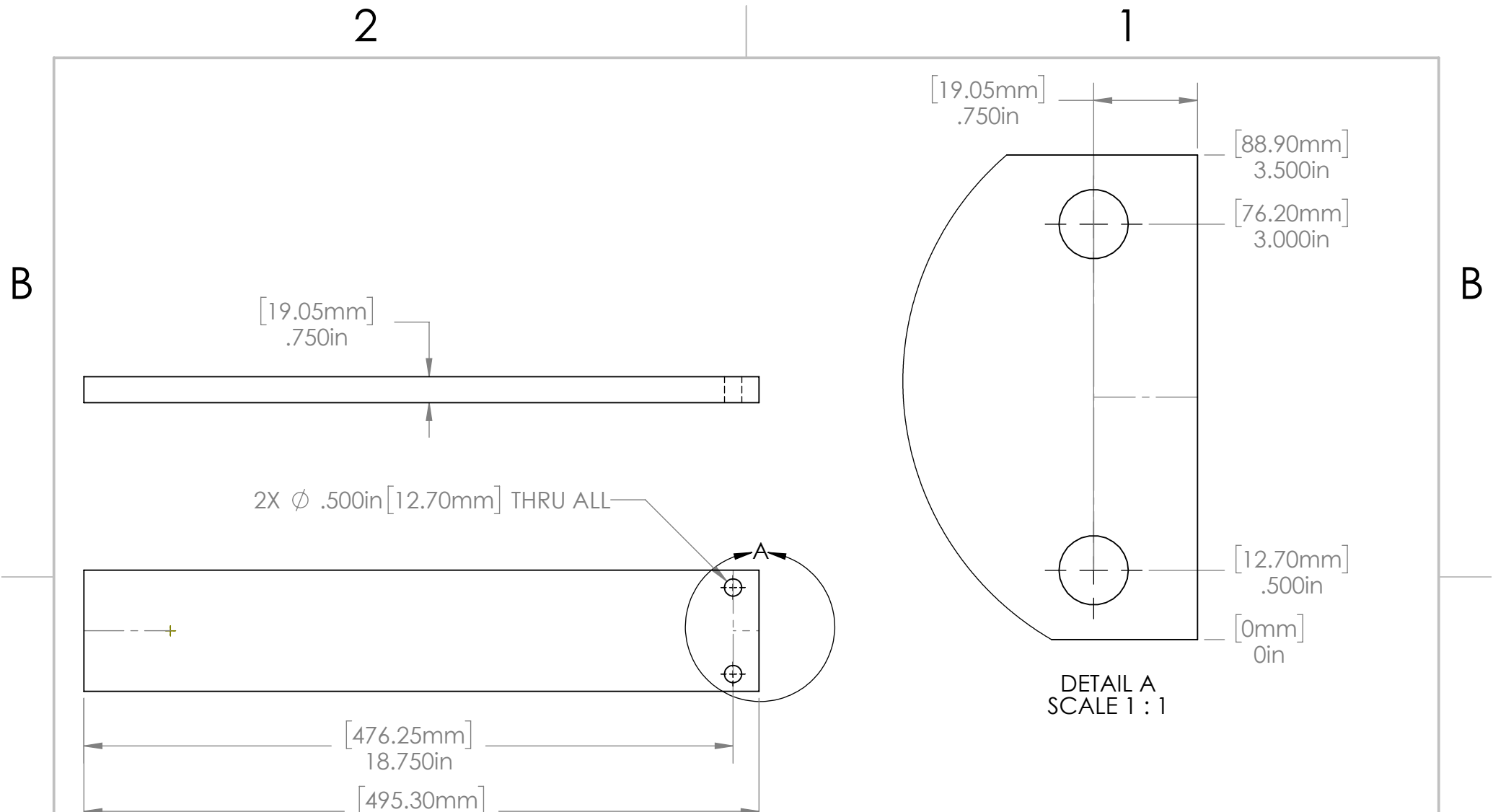

2X ϕ .500in [12.70mm] THRU ALL

DETAIL A
SCALE 1 : 1

[476.25mm]
18.750in

[495.30mm]
19.500in

[19.05mm]
.750in

[88.90mm]
3.500in

[76.20mm]
3.000in

[12.70mm]
.500in

[0mm]
0in

<p>OPEN SOURCE HARDWARE LICENSE LGPL</p>			UNLESS OTHERWISE SPECIFIED:		NAME	DATE	<p>TITLE: Bottom Tongue Board 1 Required 3/4" x 3-1/2" Pine</p>		
			DIMENSIONS ARE IN INCHES	DRAWN					
			TOLERANCES:	CHECKED					
			FRACTIONAL \pm	ENG APPR.					
		ANGULAR: MACH \pm BEND \pm	MFG APPR.				SIZE	DWG. NO.	REV
		TWO PLACE DECIMAL \pm	Q.A.				<p>reprap A belt_stretch_test_sto</p>		
		THREE PLACE DECIMAL \pm	COMMENTS:						
		INTERPRET GEOMETRIC TOLERANCING PER:							
		MATERIAL	Material <not specified>						
		FINISH							
		NEXT ASSY	USED ON						
		APPLICATION		DO NOT SCALE DRAWING					

SCALE: 1:8 WEIGHT: 13.807 SHEET 4 OF 11

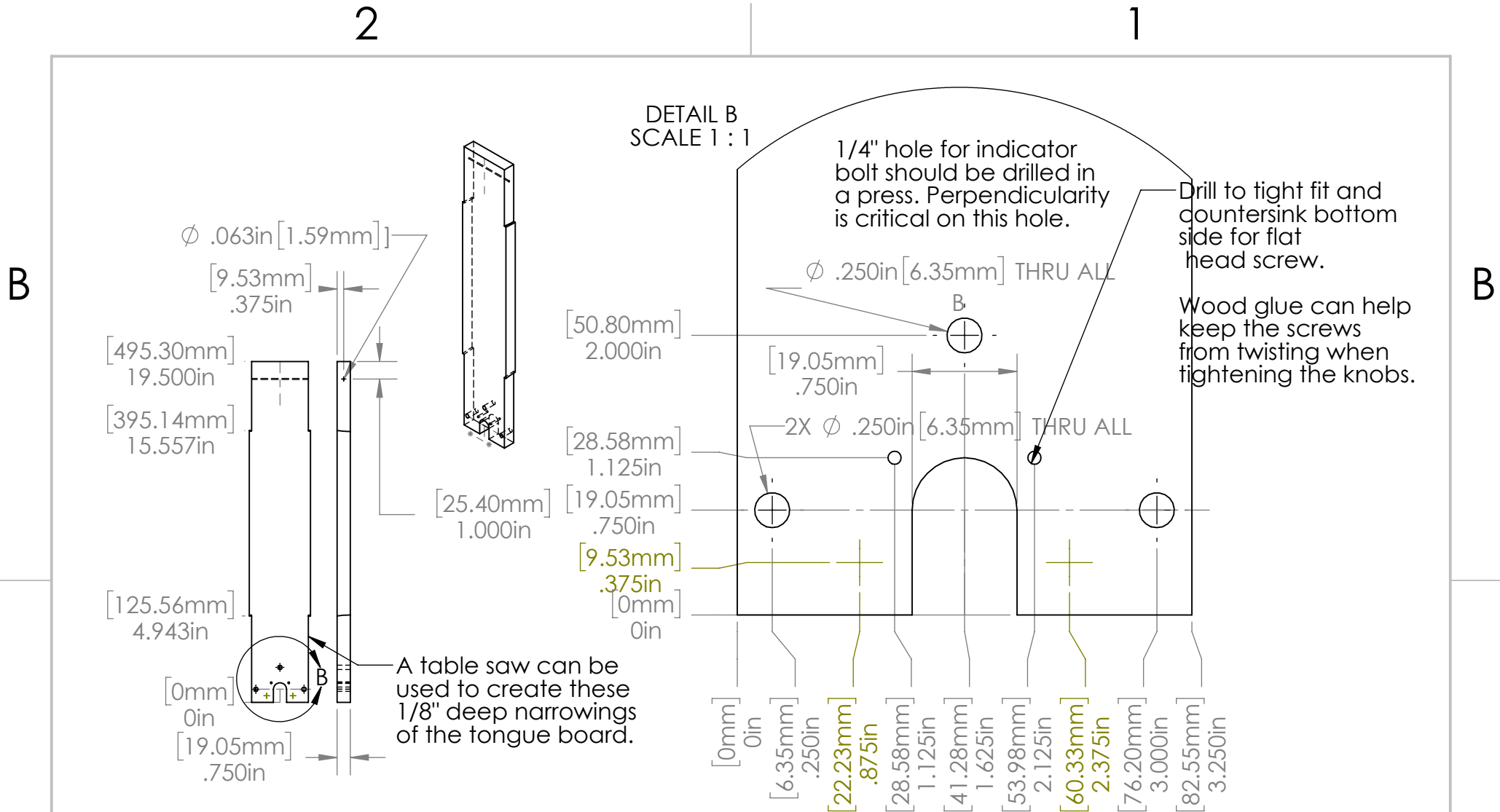

<p>OPEN SOURCE HARDWARE LICENSE LGPL</p>	UNLESS OTHERWISE SPECIFIED:		NAME	DATE	<p>TITLE: Top Tongue Board 1 Required 3/4" x 3-1/2" Pine</p>
	DIMENSIONS ARE IN INCHES		DRAWN		
	TOLERANCES:		CHECKED		
	FRACTIONAL ±		ENG APPR.		
ANGULAR: MACH ± BEND ±		MFG APPR.			<p>SIZE DWG. NO. REV</p>
TWO PLACE DECIMAL ±		Q.A.			
THREE PLACE DECIMAL ±		COMMENTS:			<p>reprap_1 Belt_stretch_test_sto</p>
INTERPRET GEOMETRIC TOLERANCING PER:					
MATERIAL					
NEXT ASSY	USED ON	FINISH		SCALE: 1:8 WEIGHT: 13.807 SHEET 5 OF 11	
APPLICATION		DO NOT SCALE DRAWING			

2

1

B

B

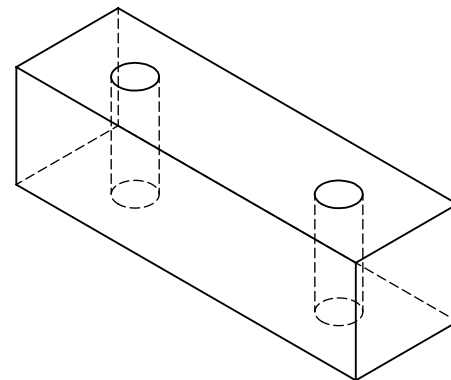
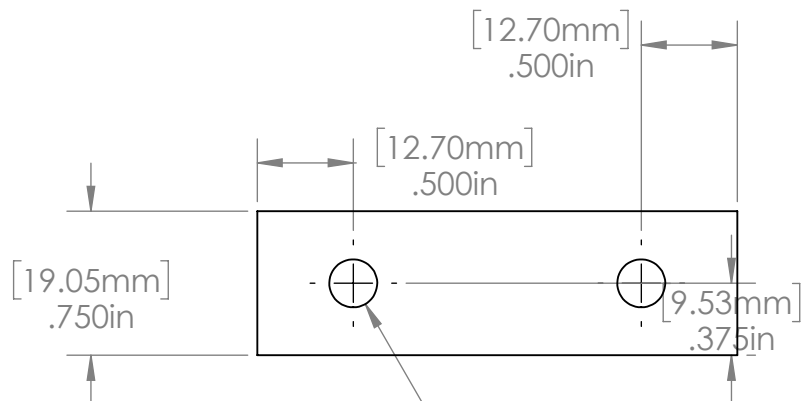

2X ϕ .250in [6.35mm] THRU ALL

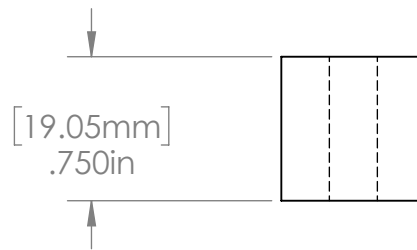
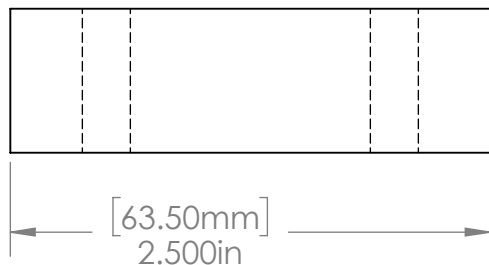

A

A

		UNLESS OTHERWISE SPECIFIED:		NAME	DATE
		DIMENSIONS ARE IN INCHES	DRAWN		
		TOLERANCES:	CHECKED		
		FRACTIONAL \pm	ENG APPR.		
		ANGULAR: MACH \pm BEND \pm	MFG APPR.		
		TWO PLACE DECIMAL \pm	Q.A.		
		THREE PLACE DECIMAL \pm	COMMENTS:		
		INTERPRET GEOMETRIC TOLERANCING PER:			
		MATERIAL	reprap_A		
		Material <not specified>	elt_stretch_test_sto		
NEXT ASSY	USED ON	FINISH	SIZE	DWG. NO.	REV
APPLICATION		DO NOT SCALE DRAWING	SCALE: 2:1 WEIGHT: 0.377 SHEET 7 OF 11		

PROPRIETARY AND CONFIDENTIAL
 THE INFORMATION CONTAINED IN THIS DRAWING IS THE SOLE PROPERTY OF <INSERT COMPANY NAME HERE>. ANY REPRODUCTION IN PART OR AS A WHOLE WITHOUT THE WRITTEN PERMISSION OF <INSERT COMPANY NAME HERE> IS PROHIBITED.

2

1

2

1

B

B

A

A

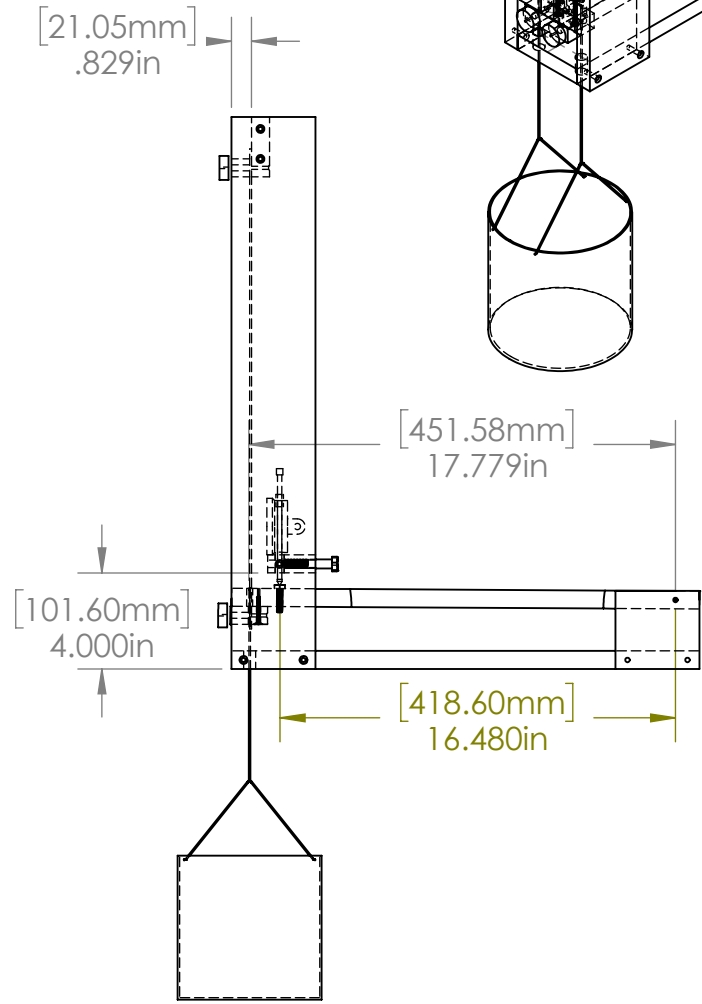
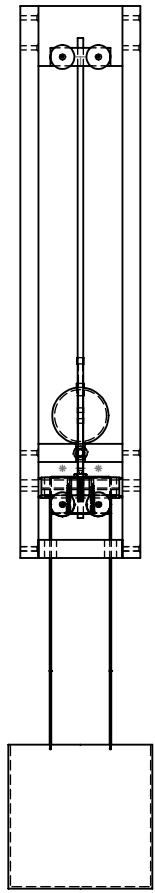
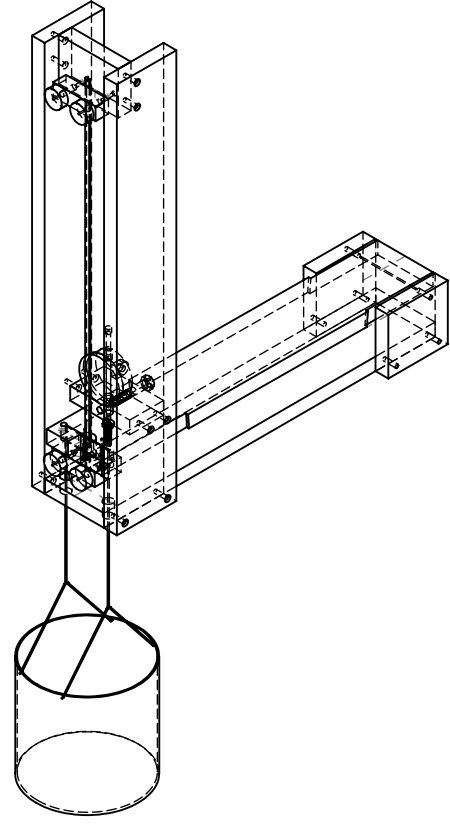
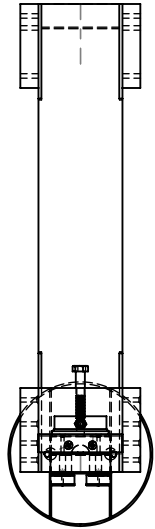

PROPRIETARY AND CONFIDENTIAL
 THE INFORMATION CONTAINED IN THIS DRAWING IS THE SOLE PROPERTY OF <COMPANY NAME>. ANY REPRODUCTION IN PART OR AS A WHOLE WITHOUT THE WRITTEN PERMISSION OF <COMPANY NAME> IS PROHIBITED.

		DIMENSIONS ARE IN INCHES TOLERANCES: FRACTIONAL ± ANGULAR: MACH ± BEND ± TWO PLACE DECIMAL ± THREE PLACE DECIMAL ±		NAME	DATE
		MATERIAL Material <not specified>		DRAWN	
		FINISH		CHECKED	
NEXT ASSY	USED ON			ENG APPR.	
APPLICATION		DO NOT SCALE DRAWING		MFG APPR.	
				Q.A.	
				COMMENTS:	
				SIZE	DWG. NO.
				SCALE: 1:12	WEIGHT: 73.320
				REV.	
				SHEET 8 OF 11	

rearap_belt_stretch_test_stand

2

1

2

1

B

B

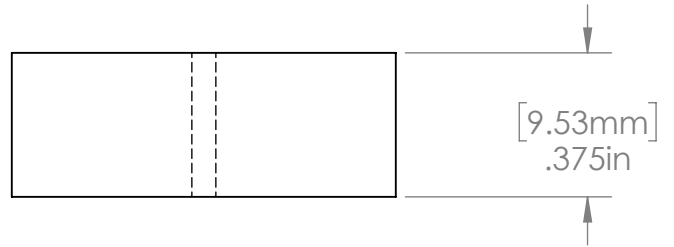
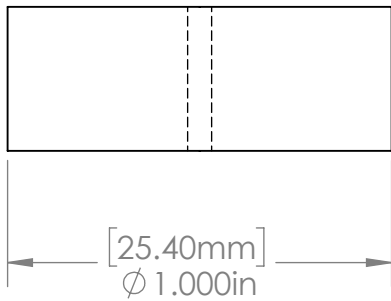
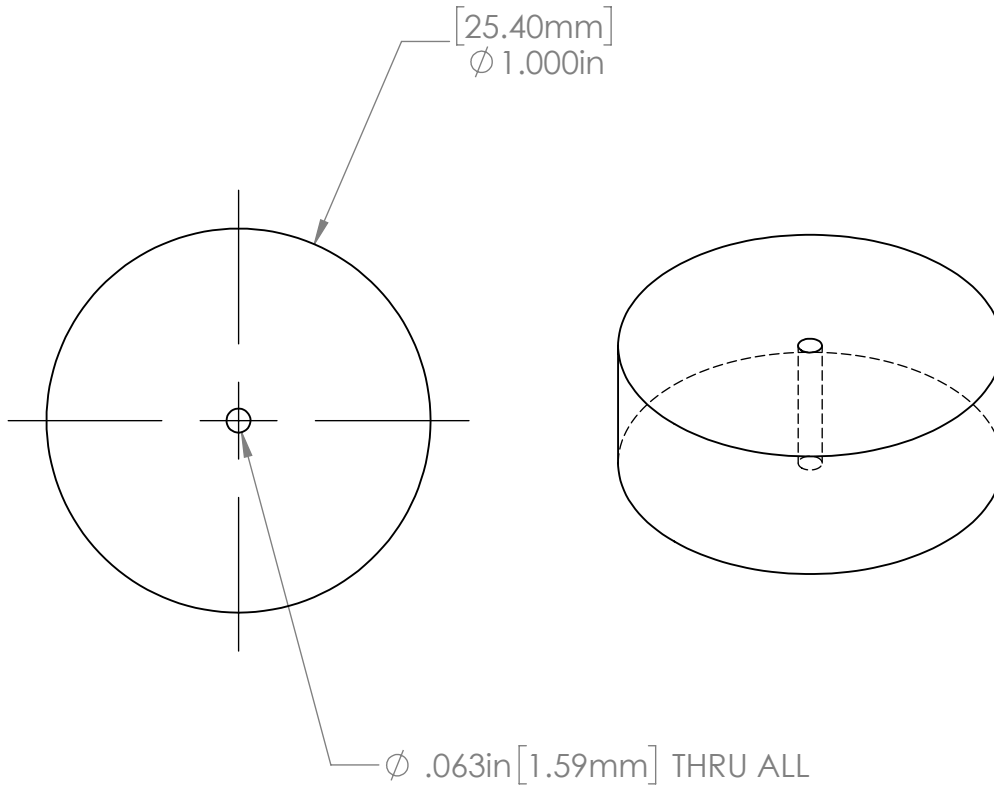

A

A

OPEN SOURCE HARDWARE
LICENSE LGPL

		DIMENSIONS ARE IN INCHES TOLERANCES: FRACTIONAL ± ANGULAR: MACH ± BEND ± TWO PLACE DECIMAL ± THREE PLACE DECIMAL ±		NAME	DATE
		MATERIAL Material <not specified>		DRAWN	
		FINISH		CHECKED	
NEXT ASSY	USED ON			ENG APPR.	
				MFG APPR.	
				Q.A.	
				COMMENTS:	
APPLICATION		DO NOT SCALE DRAWING			

Knob
4 Required
Plywood

SIZE	DWG. NO.	REV.
SCALE:2:1	WEIGHT: 0.083	SHEET 9 OF 11

2

1

rear_belt_stretch_test_stanc

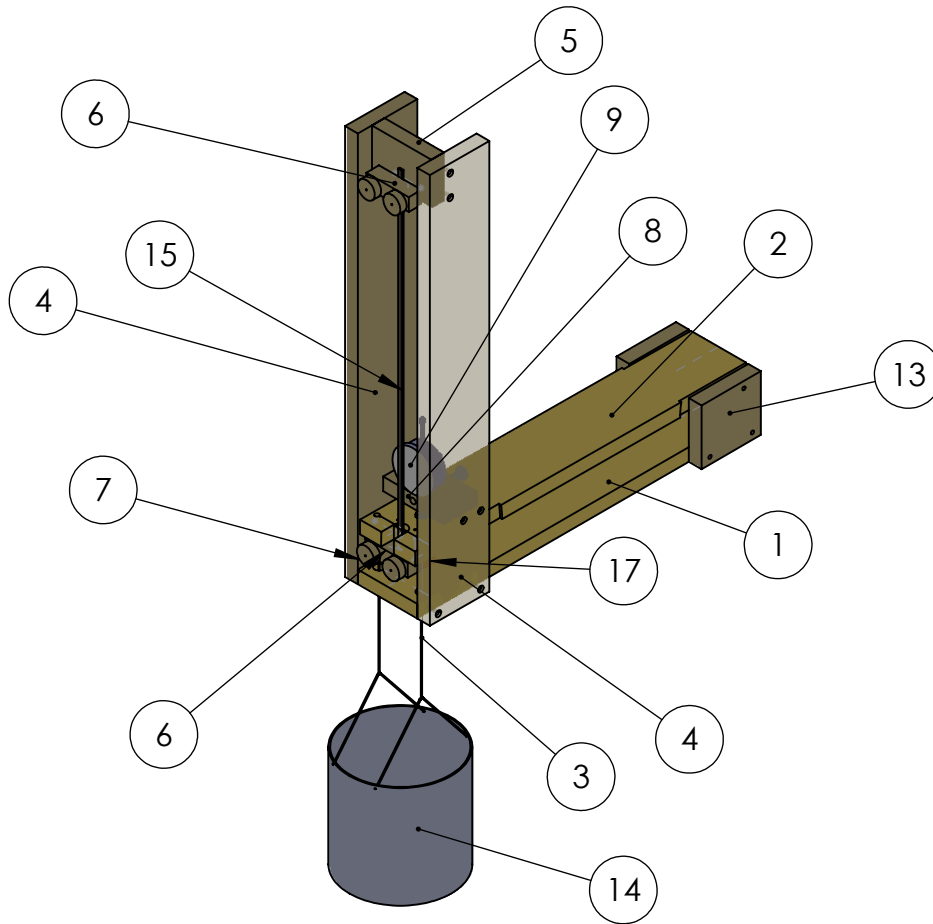

ITEM NO.	PART NUMBER	QTY.
1	upper pivoting tongue	1
2	lower_tongue (fixed)	1
3	string	1
4	upright	2
5	frame_top_block	1
6	belt_clamp_block	2
7	knob	4
8	indicator_mount	1
9	Dial_indicator_body-Harbor_Freight_Item623	1
10	Dial_indicator_body-Harbor_Freight_Item623	1
11	91247A632	1
12	92865A542	1
13	hinge_plate	2
14	weight_hopper	1
15	belt	1
16	99136A200	2
17	belt_clamp_block_lower	1

2

1

B

B

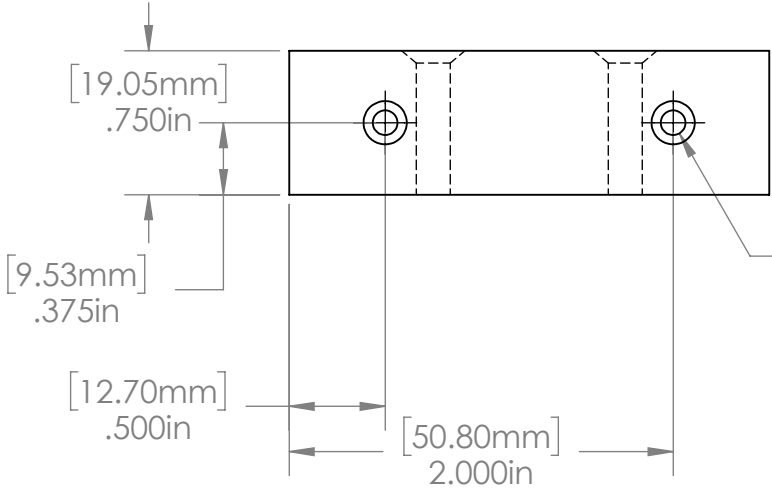

2X ϕ .129in [3.26mm] THRU ALL
 \surd ϕ .225in [5.72mm] X 100°

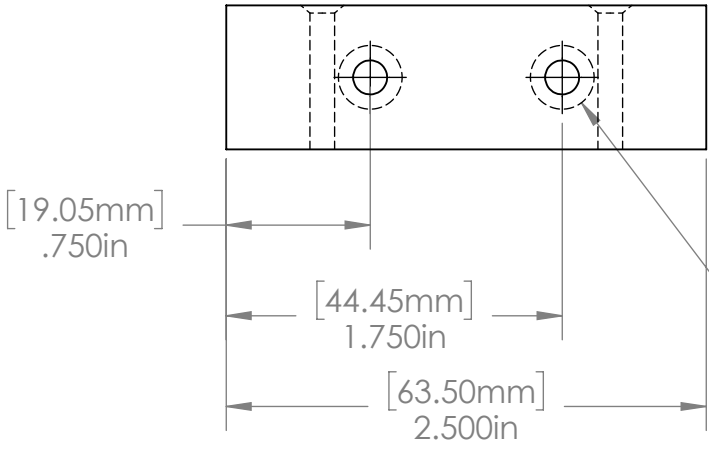
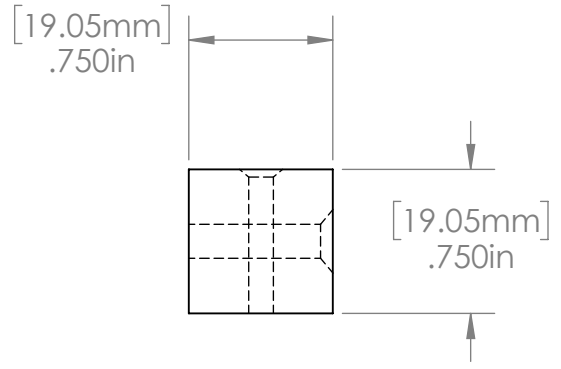
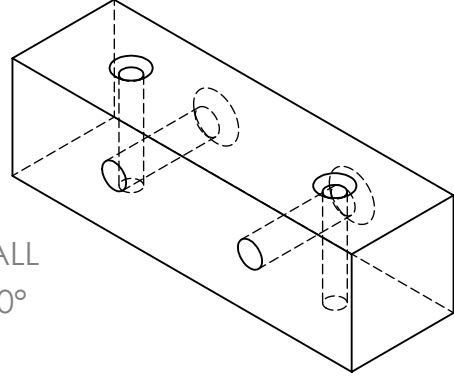

2X ϕ .177in [4.50mm] THRU ALL
 \surd ϕ .332in [8.43mm] X 100°

A

A

		UNLESS OTHERWISE SPECIFIED:		NAME	DATE
		DIMENSIONS ARE IN INCHES	DRAWN		
		TOLERANCES:	CHECKED		
		FRACTIONAL \pm	ENG APPR.		
		ANGULAR: MACH \pm BEND \pm	MFG APPR.		
		TWO PLACE DECIMAL \pm	Q.A.		
		THREE PLACE DECIMAL \pm	COMMENTS:		
		INTERPRET GEOMETRIC TOLERANCING PER:			
		MATERIAL	Material <not specified>		
NEXT ASSY	USED ON	FINISH			
APPLICATION		DO NOT SCALE DRAWING			

TITLE:		
SIZE	DWG. NO.	REV
A	reprap_belt_stretch_test_stand	
SCALE: 1:1	WEIGHT: 0.381	SHEET 11 OF 1

PROPRIETARY AND CONFIDENTIAL
 THE INFORMATION CONTAINED IN THIS DRAWING IS THE SOLE PROPERTY OF <INSERT COMPANY NAME HERE>. ANY REPRODUCTION IN PART OR AS A WHOLE WITHOUT THE WRITTEN PERMISSION OF <INSERT COMPANY NAME HERE> IS PROHIBITED.

2

1