

Delta Rostock mini G2 pro / G2s pro

Building Instruction

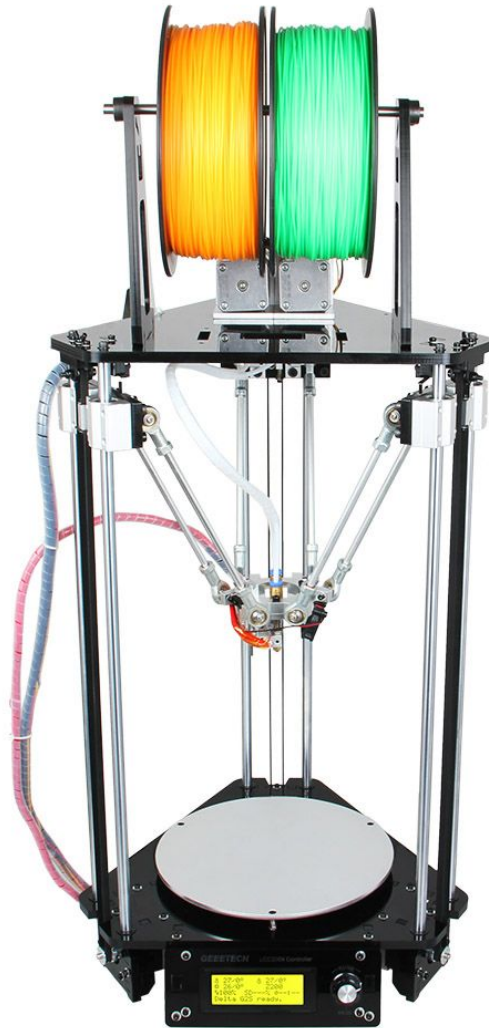

CONTENT

Safety Instructions.....	4
Preparation.....	5
1 Base Assembly.....	6
1.1 Motor holder assembly.....	6
1.2 Connect motor ends to base plate.....	8
1.3 Mount the LCD panel.....	12
1.4 Mount the fan.....	19
1.5 Mount the control board.....	21
1.6 Mount the print bed.....	23
2 Top Plate Assembly.....	28
2.1 Drive wheel mount.....	28
2.2 Endstop mount.....	29
3 Assemble the carriage.....	35
4 Assemble the print platform.....	40
4.1 mount the fan.....	40
4.2 Mount the Probe mount.....	43
4.3 Mount the rod-end bearing holder and diagonal rod.....	44
4.4. Mount the endstop and the probe.....	47
4.5 Mount the hotend.....	49
5 Mount the smooth rods.....	50
6 Mount the carriage and the top plate.....	53
7 Mount the Belt.....	55
7.1 Assemble the driving wheel.....	56
7.2 Add the belt.....	61
8 Connect the Diagonal Rod to the carriage.....	65
9 Mount the extruder.....	67



ShenZhen GETECH CO.,LTD
GEEETECH

10 Mount the filament holder.....	69
11 Connect the feeding pipe.....	72
12 Wiring.....	74
13 Tidy out the wires.....	93
14 Tips.....	95

Safety Instructions

Building the printer will require a certain amount of physical dexterity, common sense and a thorough understanding of what you are doing. We have provided this detailed instruction to help you assemble it easily.

However ultimately we cannot be responsible for your health and safety whilst building or operating the printer, with that in mind be sure you are confident with what you are doing prior to commencing with building or buying. Read the entire manual to enable you to make an informed decision.

Building and operating involves electricity, so all necessary precautions should be taken and adhered to, the printer runs on 12V supplied by a certified power supply, so you shouldn't ever have to get involved with anything over 12V but bear in mind there can still be high currents involved and even at 12V they shouldn't be taken lightly.

High temperatures are involved with 3D Printing, the Extrusion nozzle of the hot end can run about 230°C, the heated bed runs 110°C and the molten plastic extruded will initially be at around 200°C, so special care and attention should be made when handling these parts of the printer during operation.





We wouldn't recommend leaving your printer running unattended, or at least until you are confident to do so. We cannot be held responsible for any loss, damage, threat, hurt or other negligent result from either building or using the printer.

Preparation

1. Unpack the kit and check if all parts are in the box and check the condition of each part, there might be some damage during shipping. To help you with this, there is BOM in the box and each bag was labeled with part number.
2. Contact our customer service immediately by email or through the website if you find any missing or damaged parts. And on the bottom of the BOM, there is a signature of reviewer, please take a picture of it and attach the picture in your mail.
3. Read through each chapter of these instructions to gain an over-all idea of what is involved and how long it might take, before starting on the work described.
4. Before you start, you can put all the part in order to save your time especially those screws and nuts. Do not mix them up.
5. Ensure you have the necessary skills to carry out the work, or enlist the help of someone who does.
6. Work on a big firm table or bench in a clean dry well-lit area.
7. This kit contains tiny parts; please keep them away from kids under 3.
8. Ask for help if you run into any problems - our contact details are on the website and we will always do our best to resolve any problems encountered.
9. There are step-by-step videos for you to refer, please combine this instruction with the video to help you finish the work. For instruction videos, please subscribe our YouTube Channel.

1 Base Assembly

1.1 Motor holder assembly

Name	Part NO.	qty	Pic
Motor holder	NO.A3	3	
Motor holder support	NO.A4	6	
Square nut	NO.13	6	
M3 x 16 Screw	NO.20	6	
M3 washer	NO.5	6	

Step1. Assemble A3 and 2 A4 together, and screw up with M3 x 16 screws, M3 square nut and M3 washer.

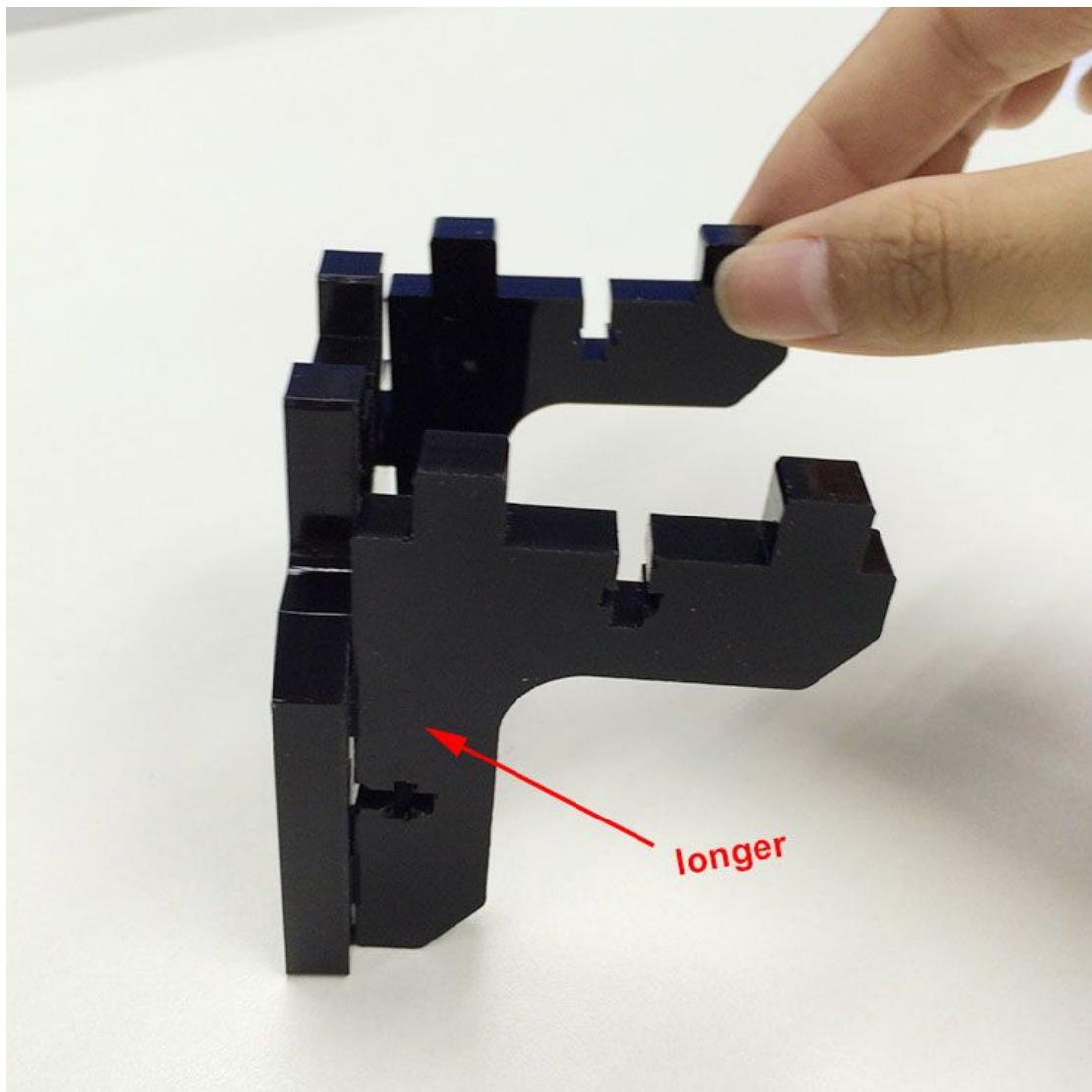

Note one side is longer and the other is shorter.





Repeat the steps for the other 2 motor holders.

[Videos](#)

1.2 Connect motor ends to base plate

Name	Part NO.	qty	Pic
Base plate	NO.A2	1	

Square nut	NO.13	9	
M3 x 16 Screw	NO.20	9	
M3 washer	NO.5	21	
Stepper motor	NO.55	3	
Pulley	NO.34	3	
M3 x 12 Screw	NO.19	12	

Step1. Mount the motor end to the 3 tower of the base plate (A2). Fix them with 9 M3 x 16 Screws, Square nuts and M3 washers.

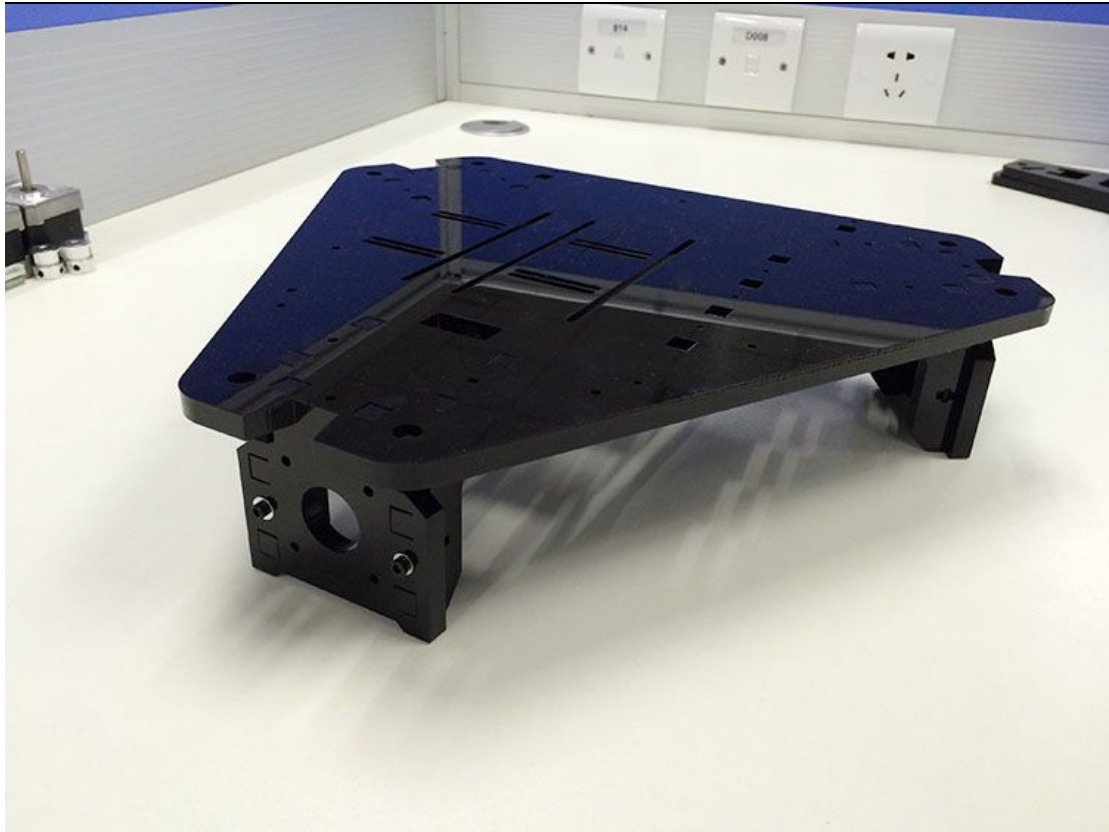

Step2. Mount the pulley on the motor shaft, one of the screws should be screwed on the cross section, the flat side of the shaft. Screw it tightly.

Tips: After tightening the primary screw against the flat side of the motor shaft, please fully tighten the remaining screw in the pulley.

Failure to do so will allow the screw to wiggle loose during printing, and will cause the pulley to jam against its acrylic enclosure.



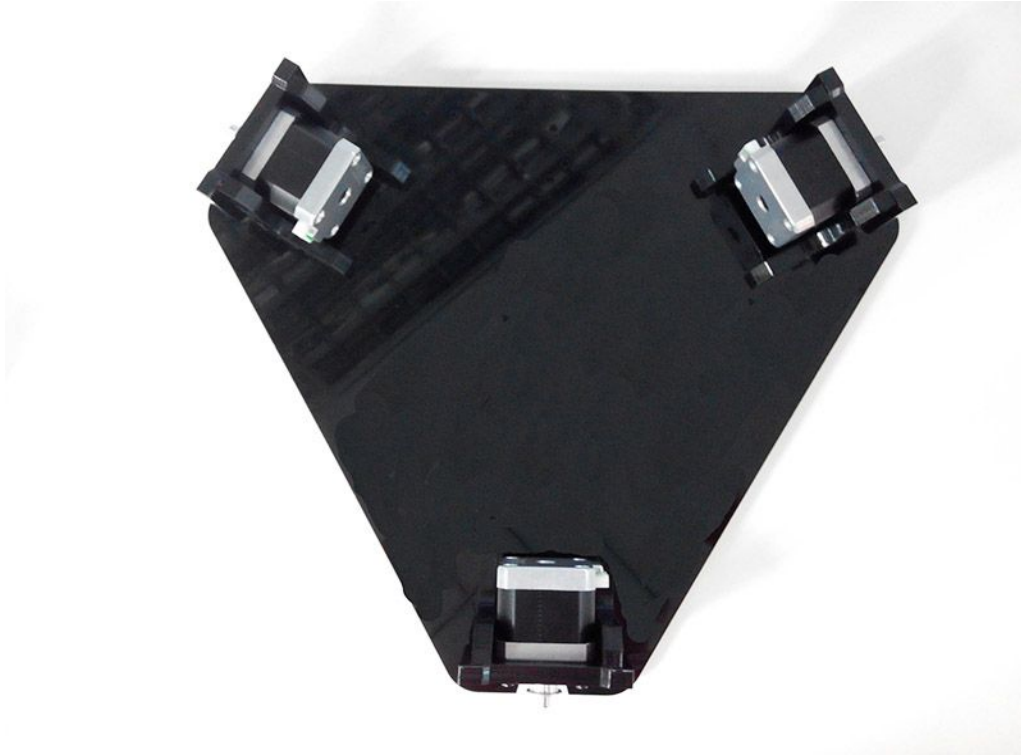

Step3. Mount the 3 assembled motor to the motor holder; screw it up with M3x12 screws and M3 washers.

* Note the direction of the wire connector, it is better to be on the either left or right side.



[Videos](#)

1.3 Mount the LCD panel

Name	Part NO.	qty	Pic
LCD frame	NO.A8	1	
LCD support	NO.A9	2	

LCD2004	NO.49	1	
Square nut	NO.13	4	
M3 x 16 Screw	NO.20	4	
M3 x 12 Screw	NO.19	4	
Spacer	NO.37	4	
M3 washer	NO.5	8	
Knob	NO.48	1	

Step1. Assemble the LCD frame and support plate together, screw up with M3 x 16 Screws and M3 square nuts.



Step2. Plug the aircraft- type spacer into the 4 screw hole on the LCD2004.

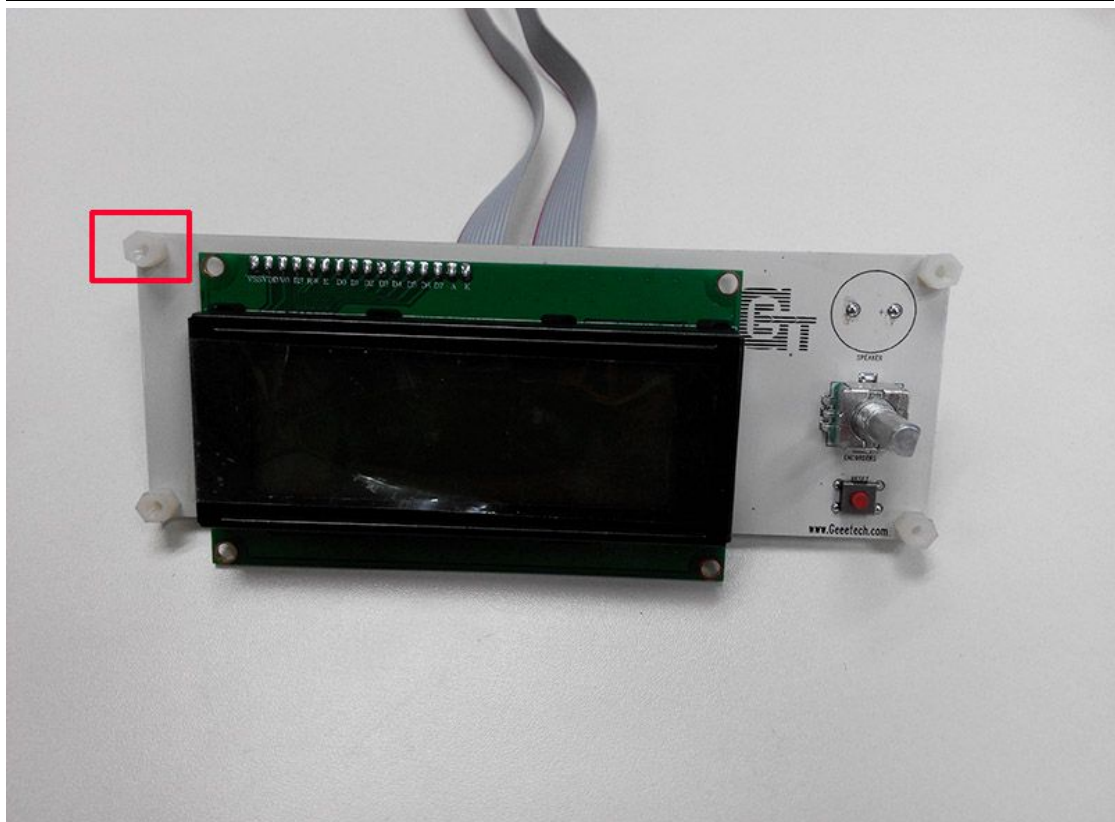

Step3. Screw up the frame and LCD2004 with 4 M3 x 12 Screws and washers.



Step4. Cover the knob and screw it up on the cross section, the screw is in the hole.











Step5. Mount the assembled LCD kit onto the base plate. Screw it up with 2 M3 x 16 screws, M3 square nuts and washers.



[Videos](#)

1.4 Mount the fan

Name	Part NO.	Qty	Pic
Fan(40x40x10)	NO.45	1	
M3 x 16 Screw	NO.20	1	
M3 x 25 screw	NO.22	2	
M3 Square nut	NO.13	1	
M3 nut	NO.10	2	
M3 washer	NO.5	3	

Step1. Mount the fan on the fan mount; screw it up with 2 M3 x 25 screw and M3 nut and washer.

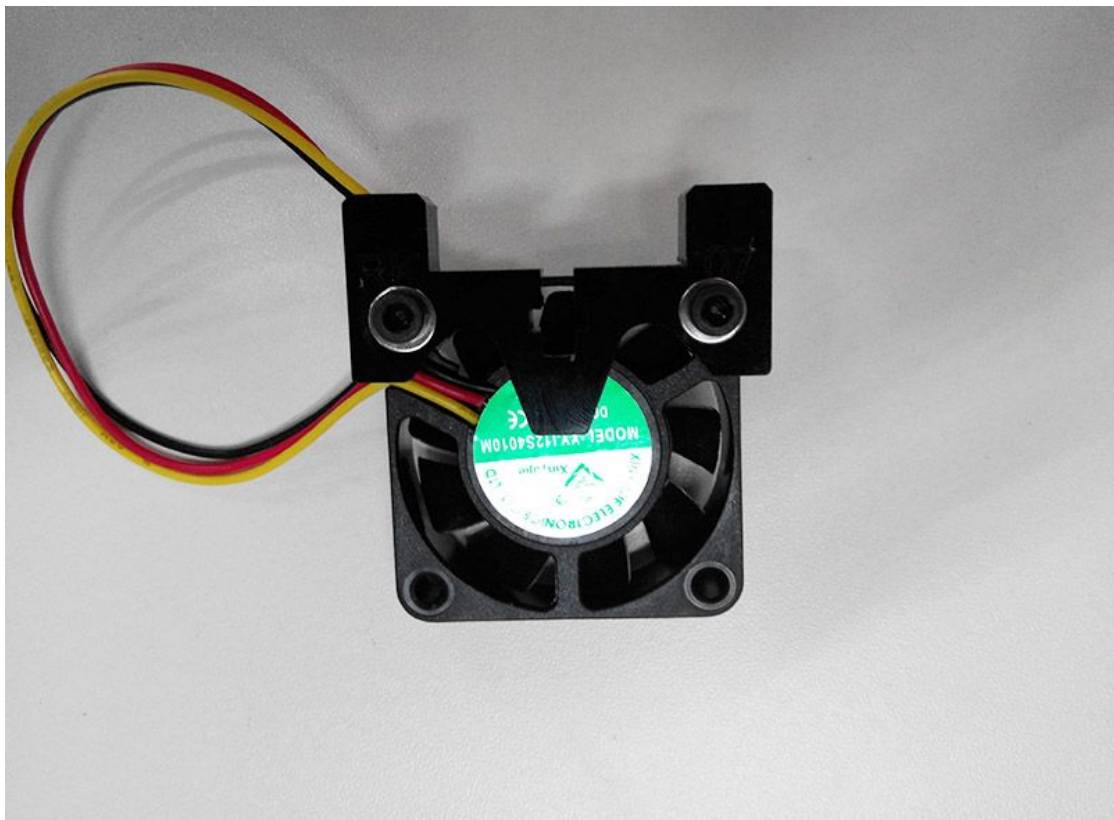



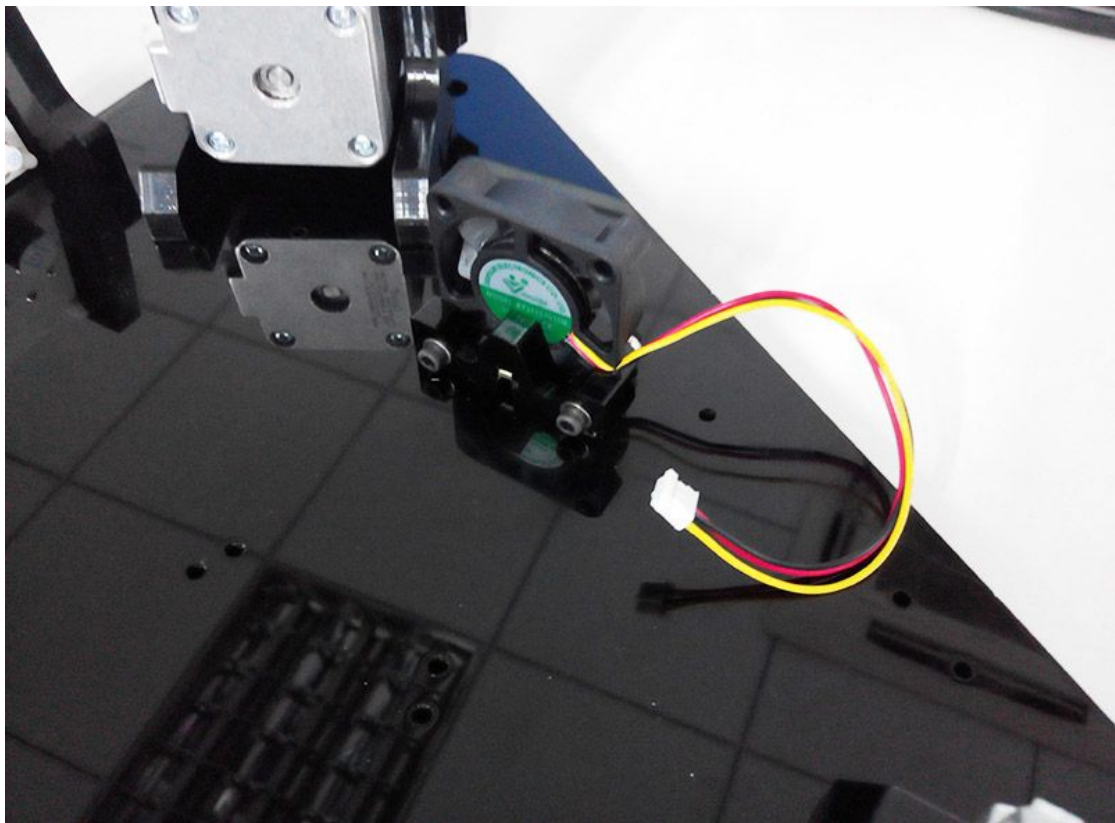

Step2. Mount the assembled fan mount on A2 with a M3 x 16 screw and M3 square nut and washer.



[Videos](#)

1.5 Mount the control board.

Name	Part NO.	Qty	Pic
Control board GT2560 set	NO.50	1	
Spacer	NO.37	4	

M3 x 12 Screw	NO.19	4	
M3 washer	NO.5	4	

Step1. Plug the aircraft- type spacer into the 4 screw hole on the control board from back to front.

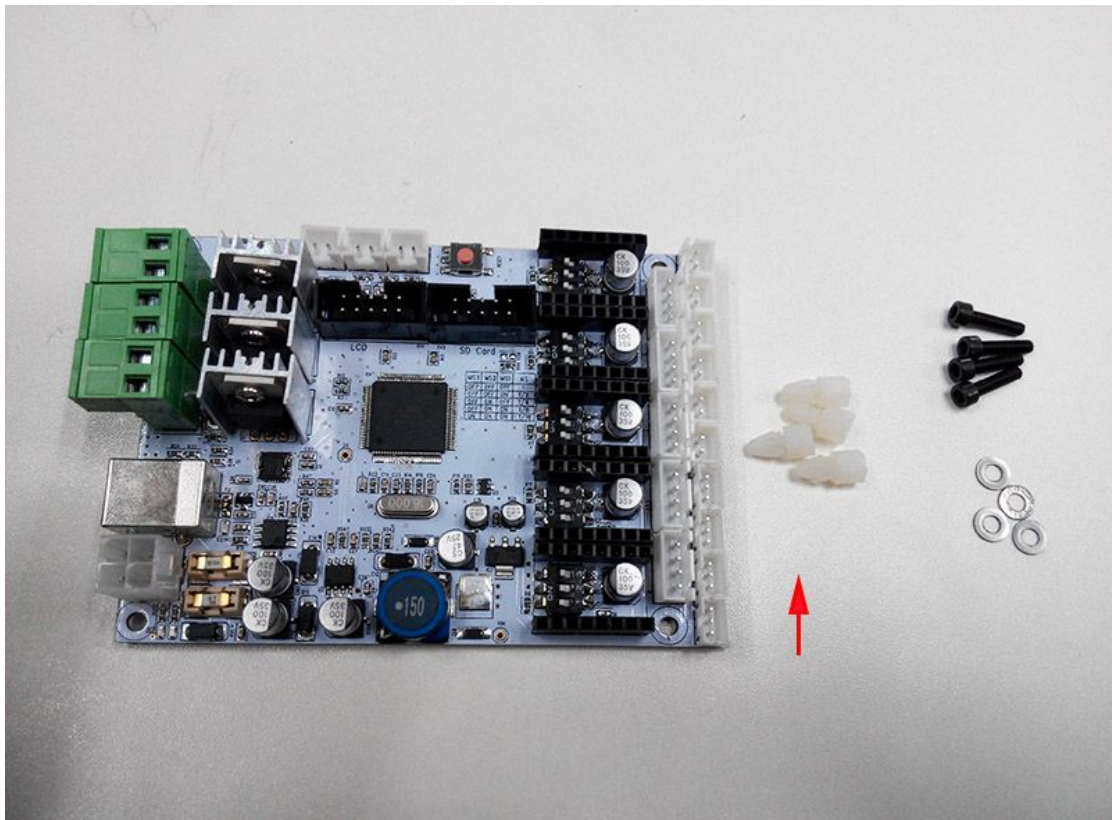

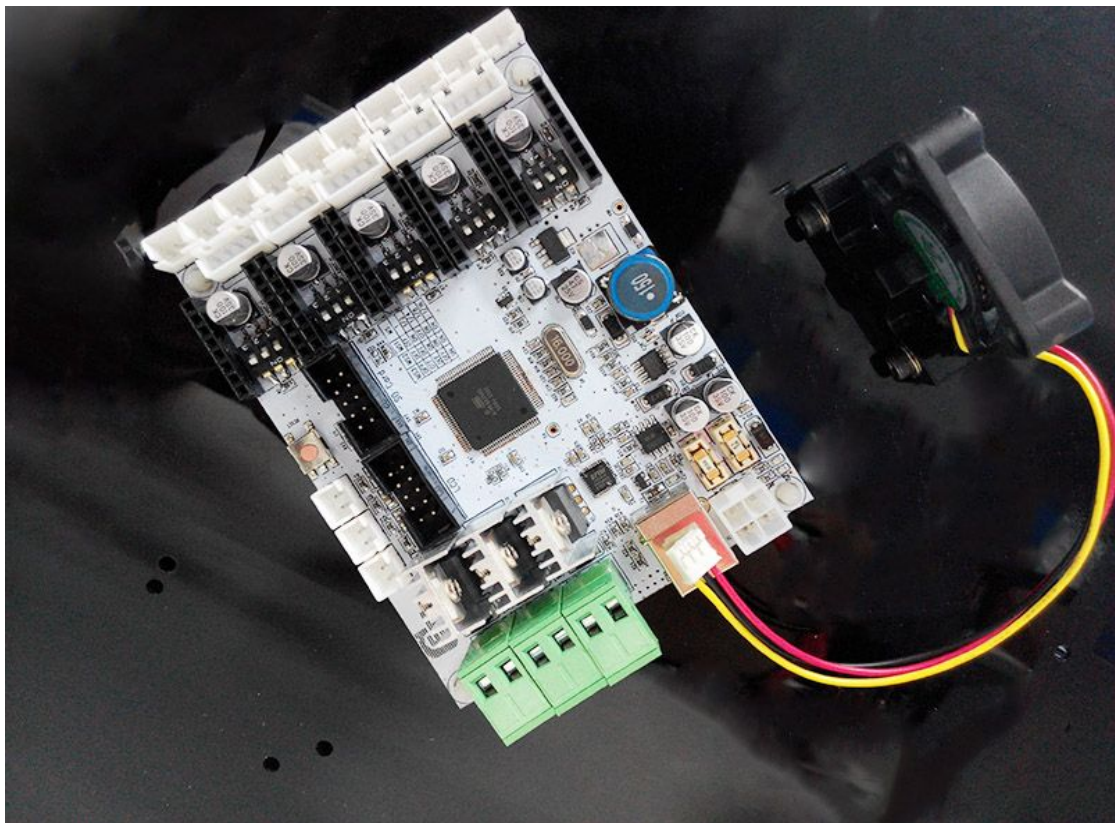

Step2. Screw the control board to the base plate (A2) with 4 M3 x 12 Screws and m3 washer.







Note the fan is better to be towards the MOSFET of the board.

[Videos](#)

1.6 Mount the print bed.

Name	Part NO.	Qty	Pic
Building platform	NO.M8	1	
Heatbed	NO.54	1	

Hex Counter- sunk-head screw	NO.14	3	
Spring 3.5 x 20mm	NO.28	3	
Wing nut	NO.12	3	
M3 washer	NO.5	6	

*for your convenience, the heatbed for you is pre-soldered, you can mount them directly.

step1. Stack the heatbed and the building platform together.



Step2. Thread the M3x30mm Hex Counter-sunk-head screw through the two plates and add washers and spring at this end.



Step3. Lock the other end with a wing nut.

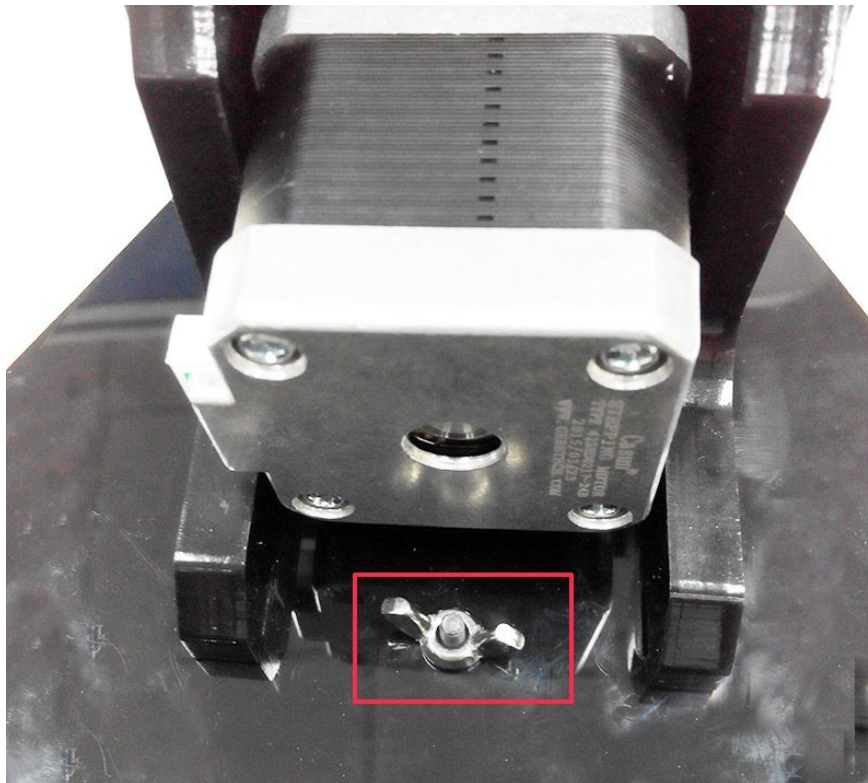

Here is the finished picture.

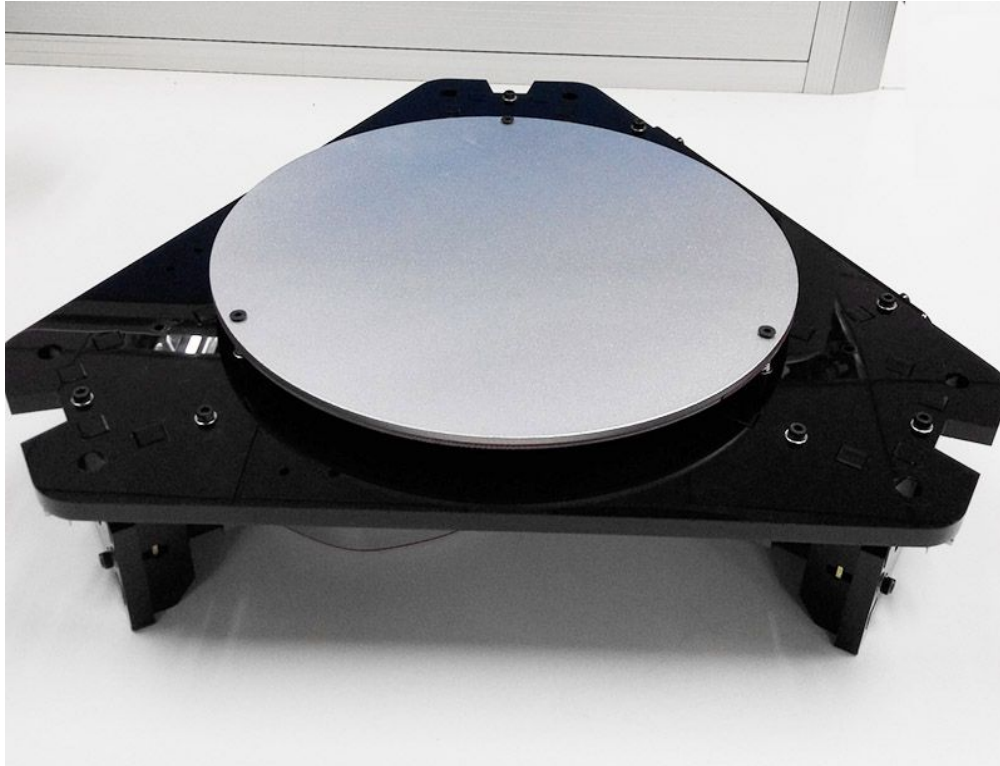

[Videos](#)





Tips:

During bed installation, use a reference height (such as a M3x12 bolt) to make sure that each top of each bed mounting point is the same after tightening the wing nuts.

Simply place a M3x12 bolt (head down) next to the bed (not under!), and tighten until the end of the bolt is at the same level as the top of the bed. Repeat for the other two mounts.

2 Top Plate Assembly

2.1 Drive wheel mount

Name	Part NO.	qty	Pic
Drive wheel mount	NO.A5	3	
M3x25 Screw	NO.22	6	
M3 nut	NO.10	6	
M3 washer	NO.5	6	



Step1. Mount the Drive wheel mount on A1; screw them up with M3 x 25 screws, M3 nut and washers.









Repeat for the other two mount.

[Videos](#)

2.2 Endstop mount

Name	Part NO.	qty	Pic
Top plate	NO.A1	1	
Endstop mount	NO.A6	3	

Endstop	NO.44	3	
M2.5 x 16 screw	NO.17	6	
M3 x 16 Screw	NO.20	3	
Square nut	NO.13	3	
M3 washer	NO.5	9	
M2.5 nut	NO.9	6	

Step1. Mount the three end stops onto the Endstop mount (A6) in the same direction, screw with M2.5 x 16 screws and M2.5 nut tightly.

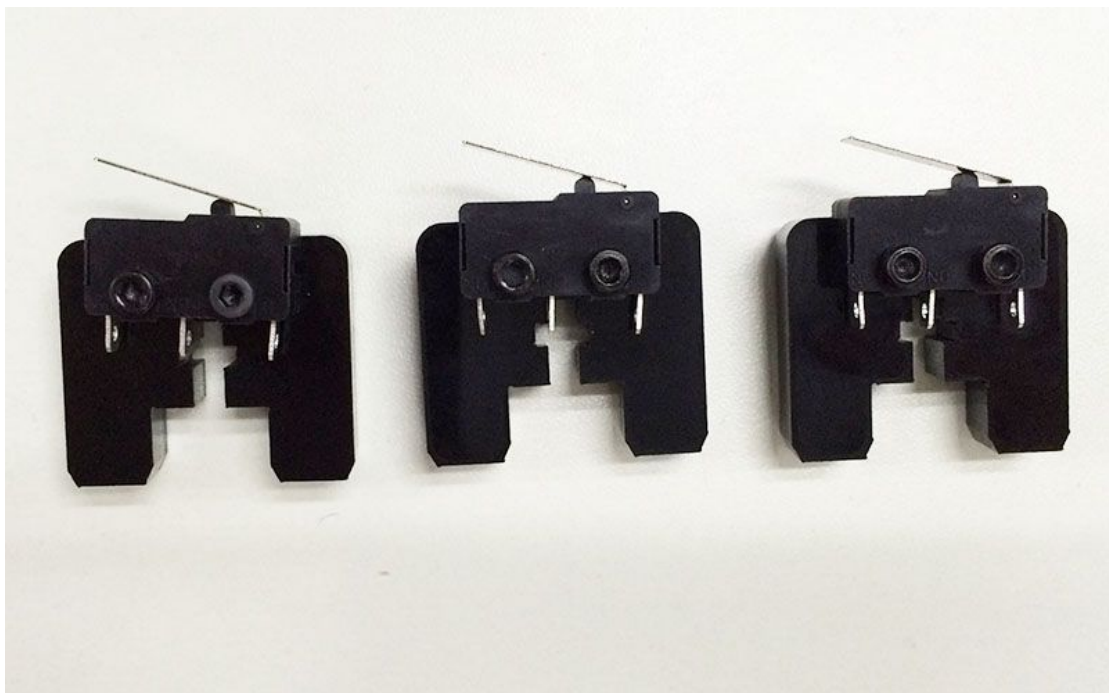

Step2. Bent the wire connector a bit.

You should do it very gently and note the direction, or it will break easily.

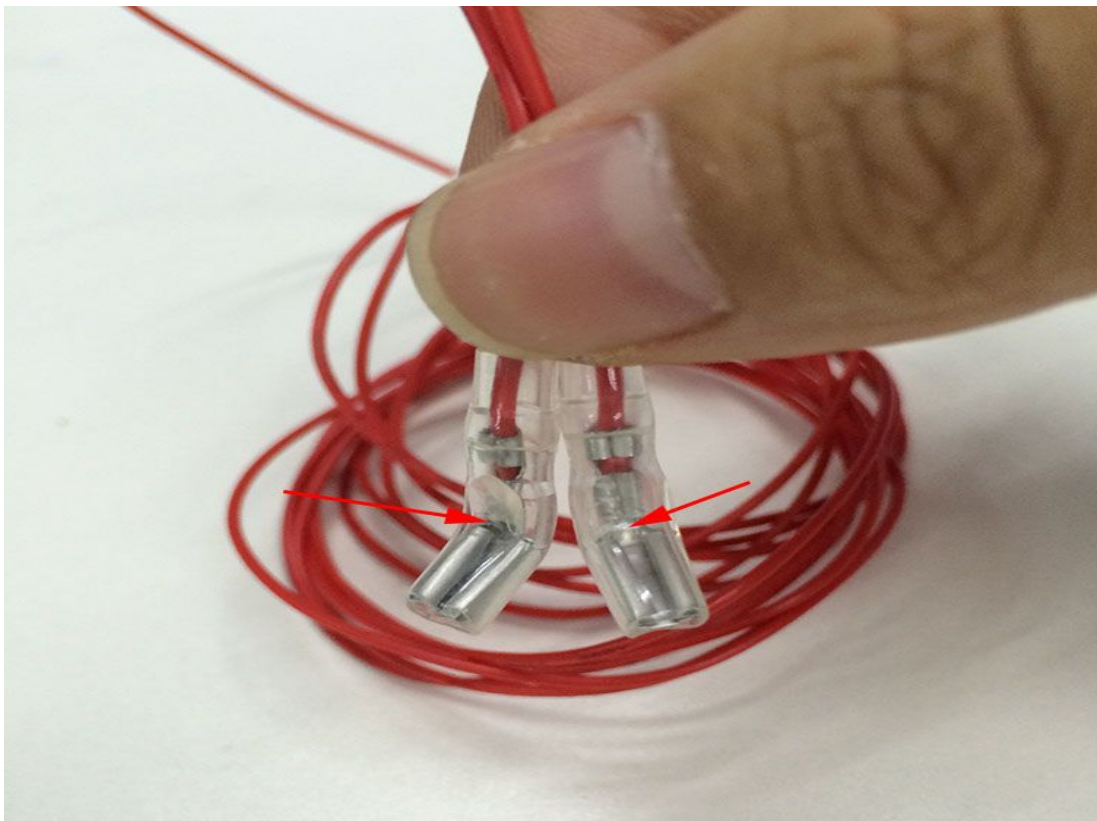

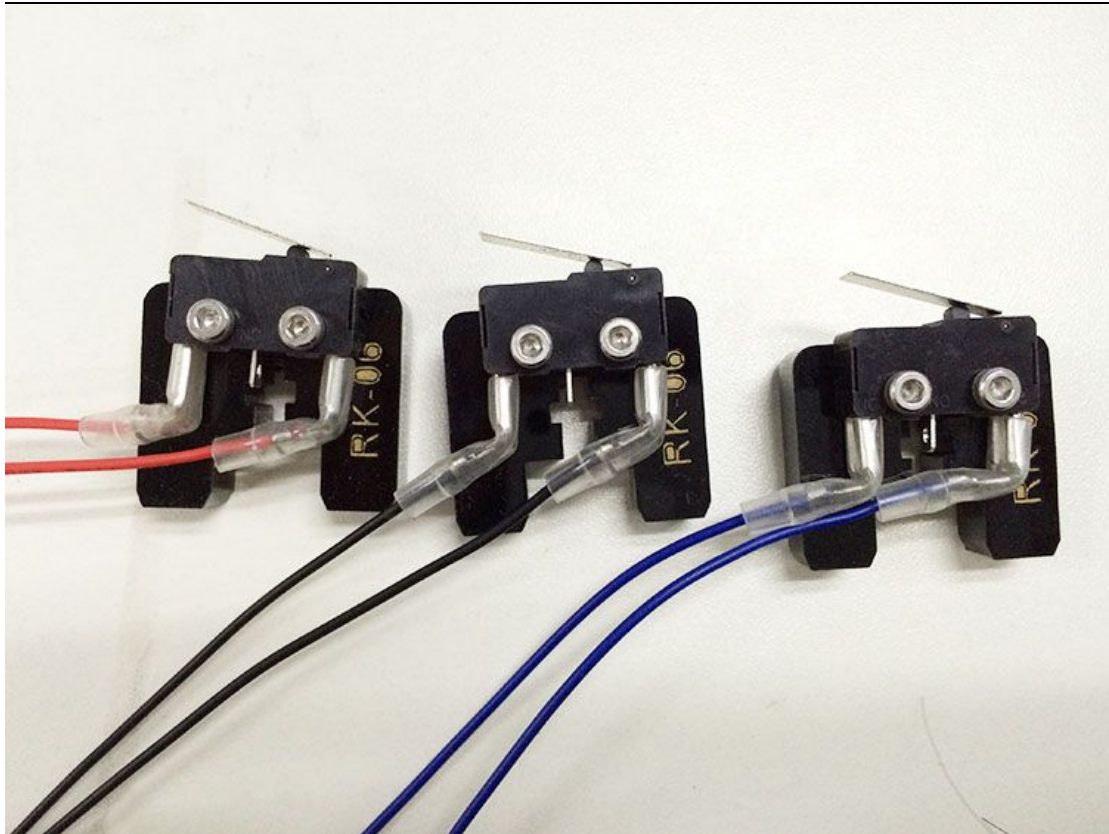

Step2. Mount the assembled parts onto the top plate. Screw up with M3 x 16 screws, M3 square nuts and M3 washers. Again,note the directions of the endstop.



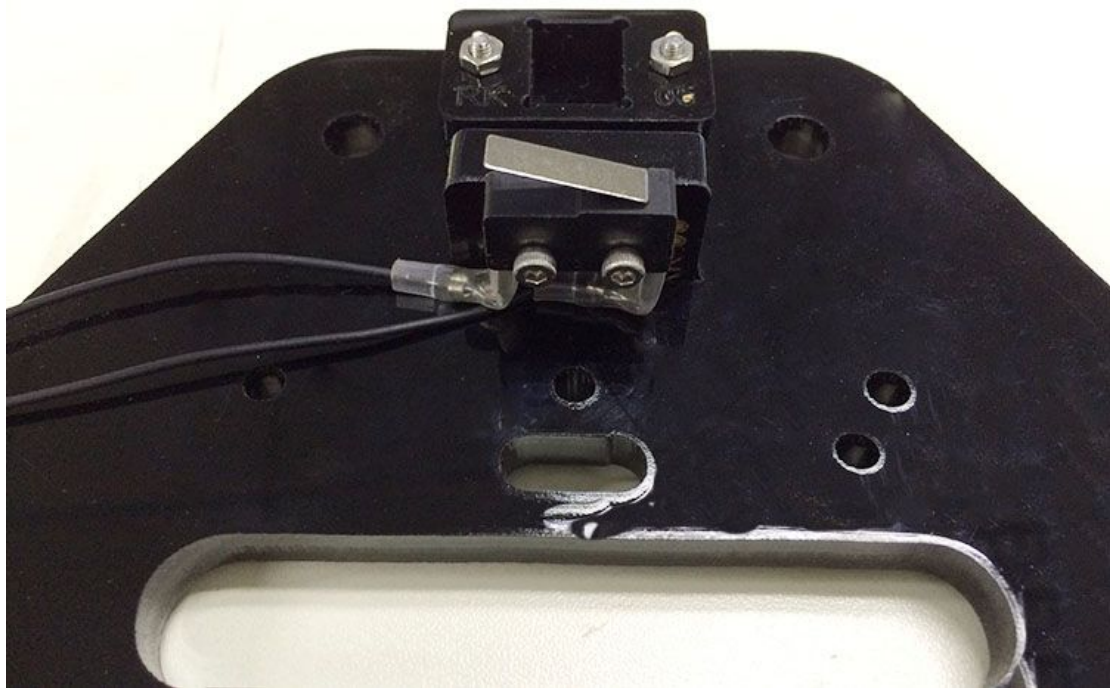
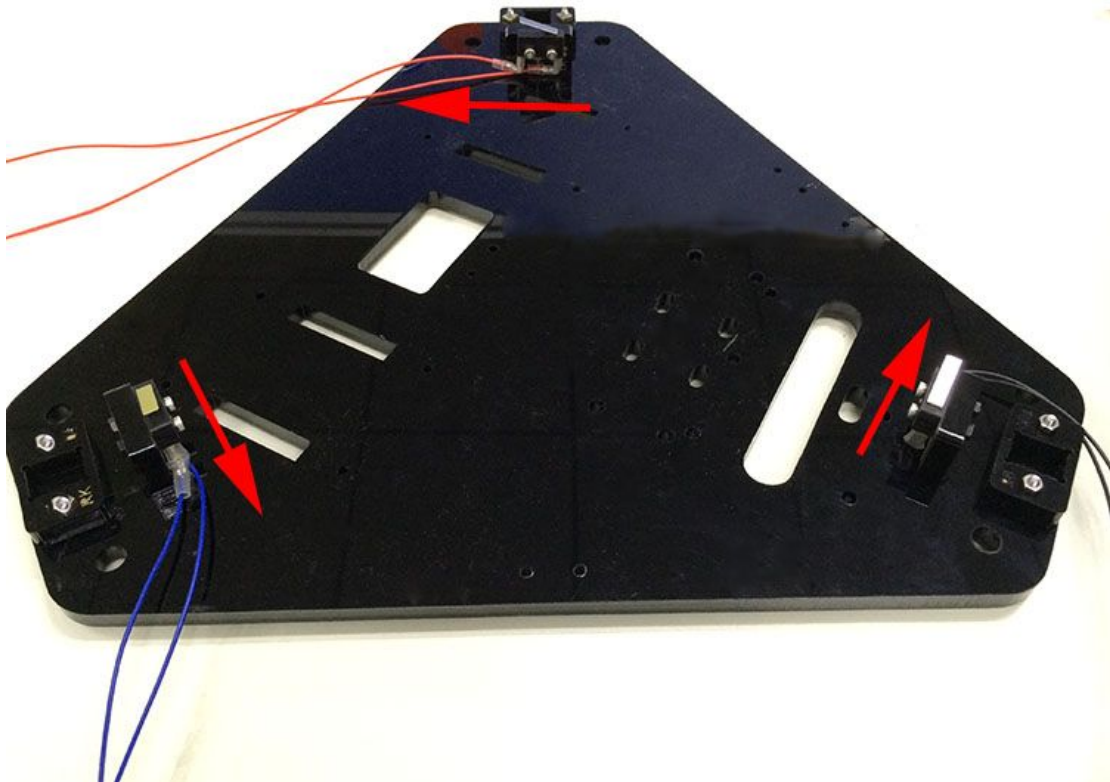

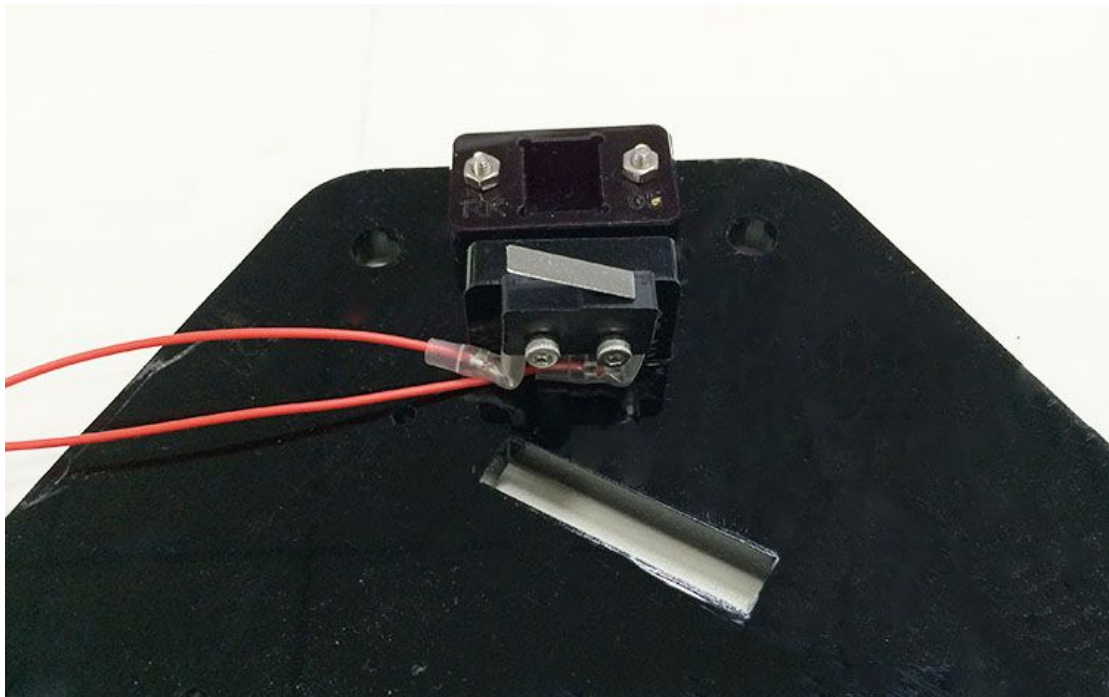
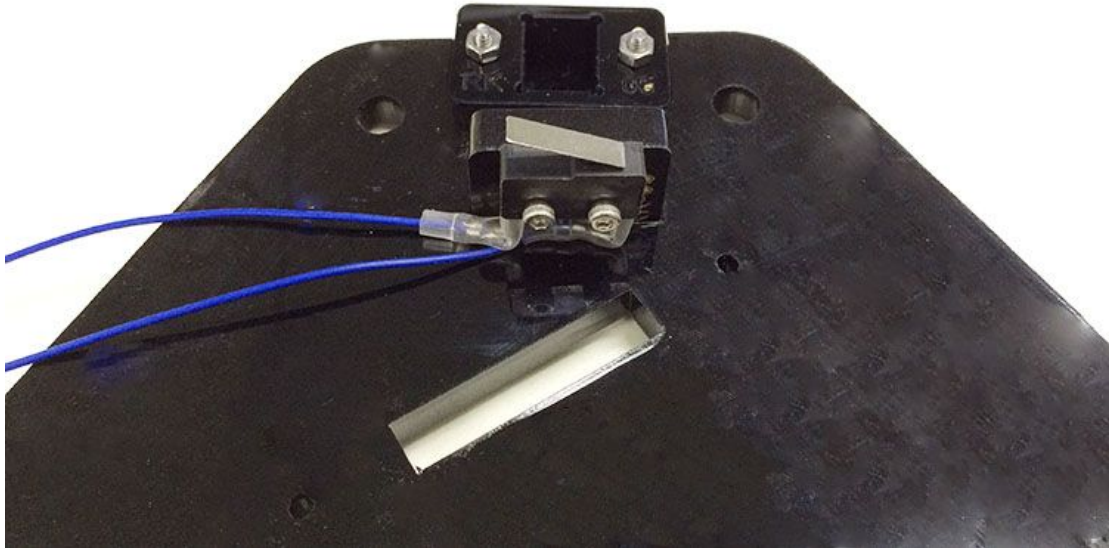



*The opening of the endstop should be in clockwise direction or anti-clockwise direction.







[Videos](#)

3 Assemble the carriage

Name	Part NO.	qty	Pic
Carriage mount	NO.A12	3	
Belt mount	NO.M5	3	
Endstop trigger mount	NO.M6	3	
Diagonal Rod joint	NO.M7	6	
SCS10UU Linear Bearing	NO.35	6	
M3x8mm Screw	NO.18	6	
M3x12mm Screw	NO.19	12	
M5x16mm Screw	NO.27	24	
M3x40mm Screw	NO.23	3	
Spring	NO.29	3	

M3 washer	NO.5	24	
rod-end bearing holder	NO.3	6	

Step1. Fix the belt mount on the A12 with 2 M3 x12 screws and washer.

Step2. Fix the Endstop trigger mount on the other side of the A12 with 2 M3 x 12mm screws and washer.

Step3. Connect the diagonal rod joint and the SCS10UU linear bearing with the A12 in between. Fix it up with 8 M5x16mm screws.

Note the direction of the diagonal rod joint, the wider edge is near the Endstop trigger mount.

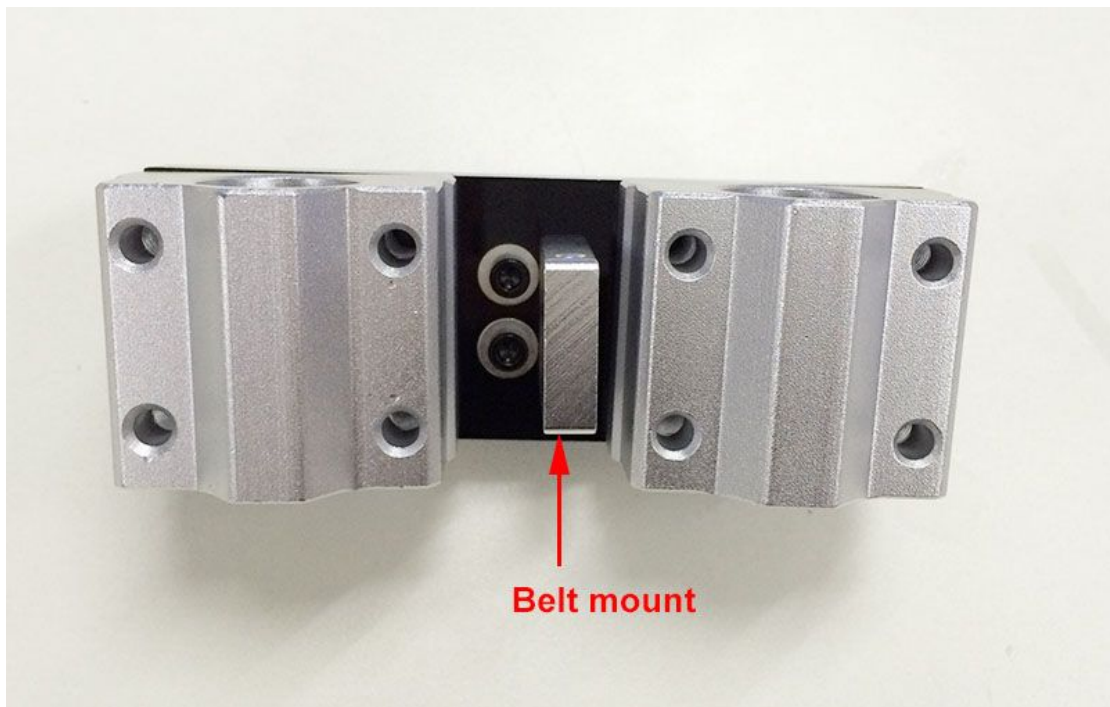
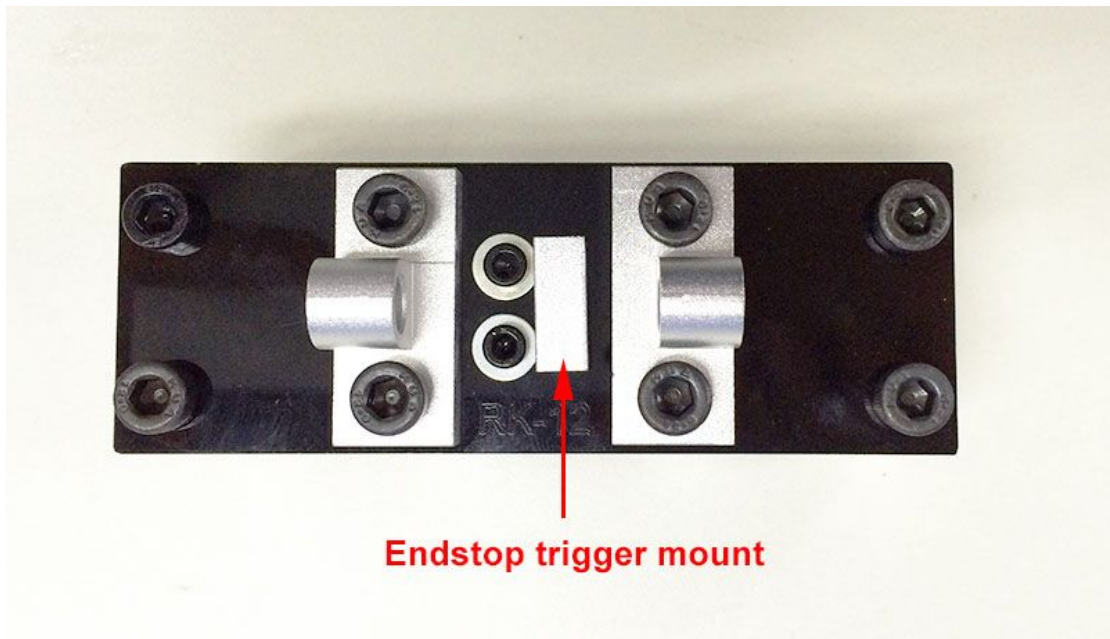



Step3. Put the M3x40mm screw into the Endstop trigger mount with a spring in between. Here you need to use washers.

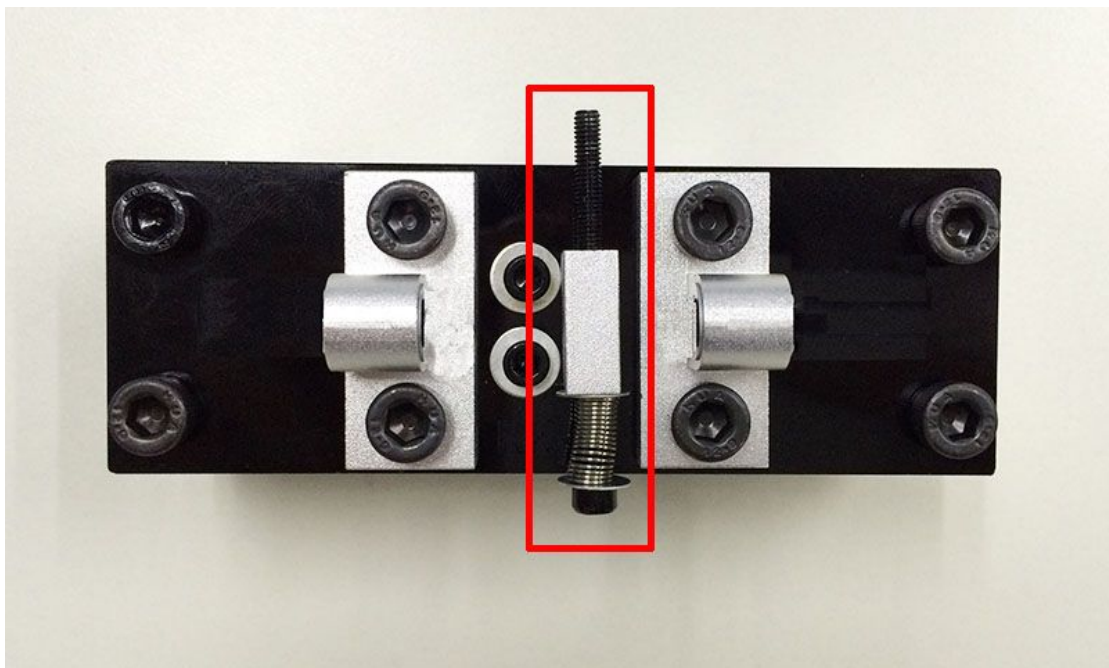

Repeat the steps for the rest two carriages.

The 3 carriages should be exactly the same.

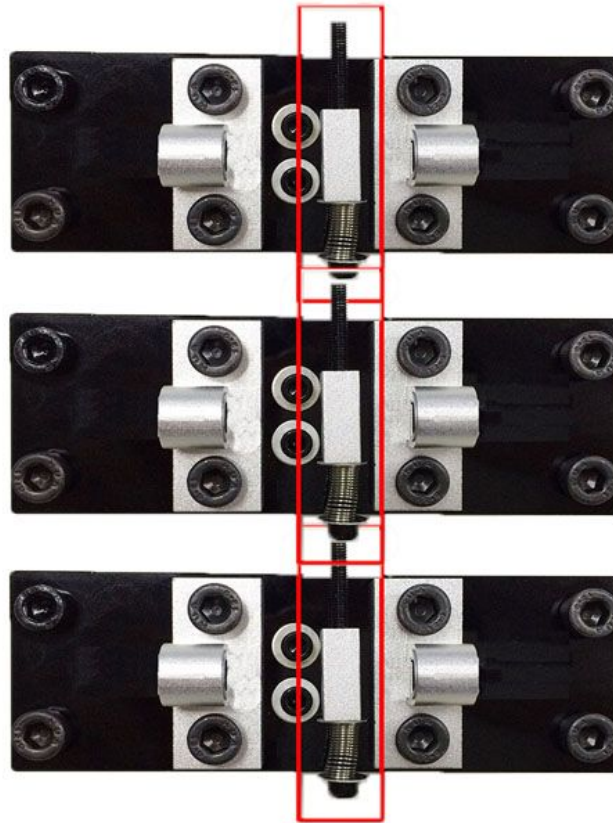

Step4. Insert the rod-end bearing holder into the diagonal rod joint, fix it with a M3x8mm screw and M3 washer.

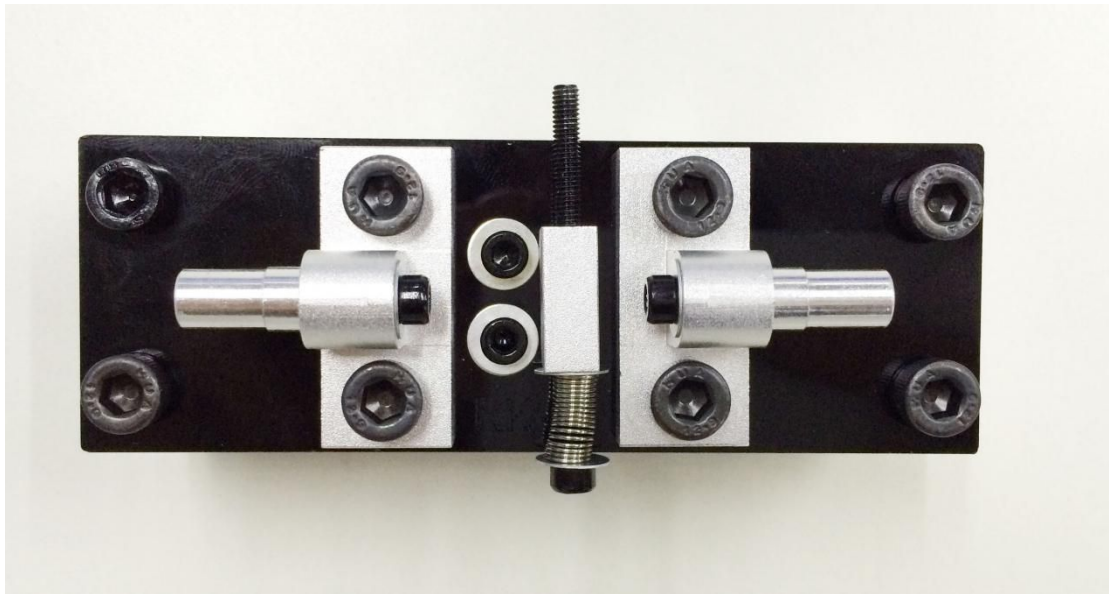

Repeat the step for the other 2 carriages.





[Videos](#)

4 Assemble the print platform

4.1 mount the fan

Name	Part NO.	Qty	Pic
Spider	NO.M1	1	
Fan (30x30x10)	NO.47	1	
Fan mount	NO.M2	1	

M3 x 16 screw	NO.20	2	
M3 x20 screw	NO.21	2	
M3 washer	NO.5	2	

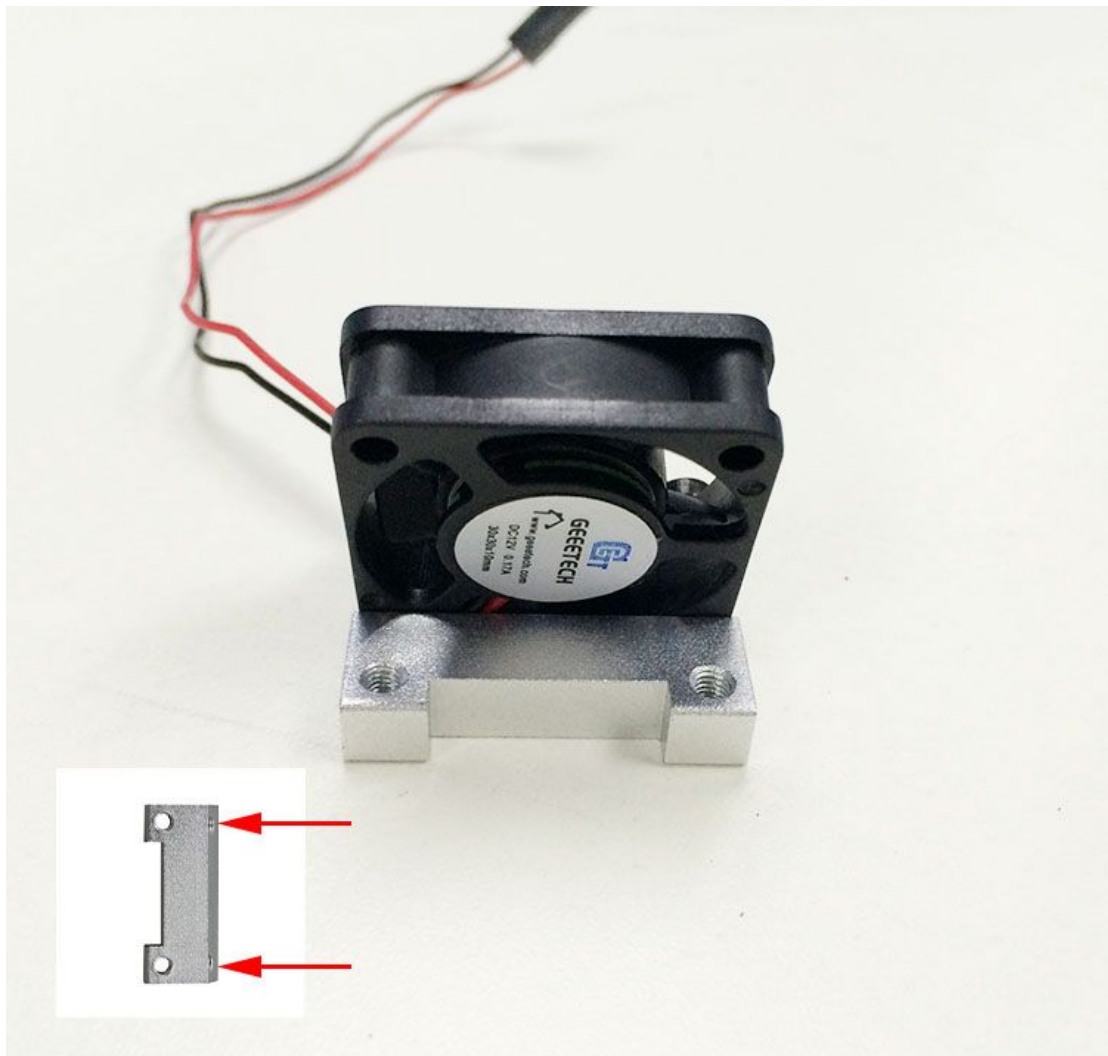

Step1. Screw the fan onto the slant side of the fan mount with 2 M3x 20 screws and M3 washers.

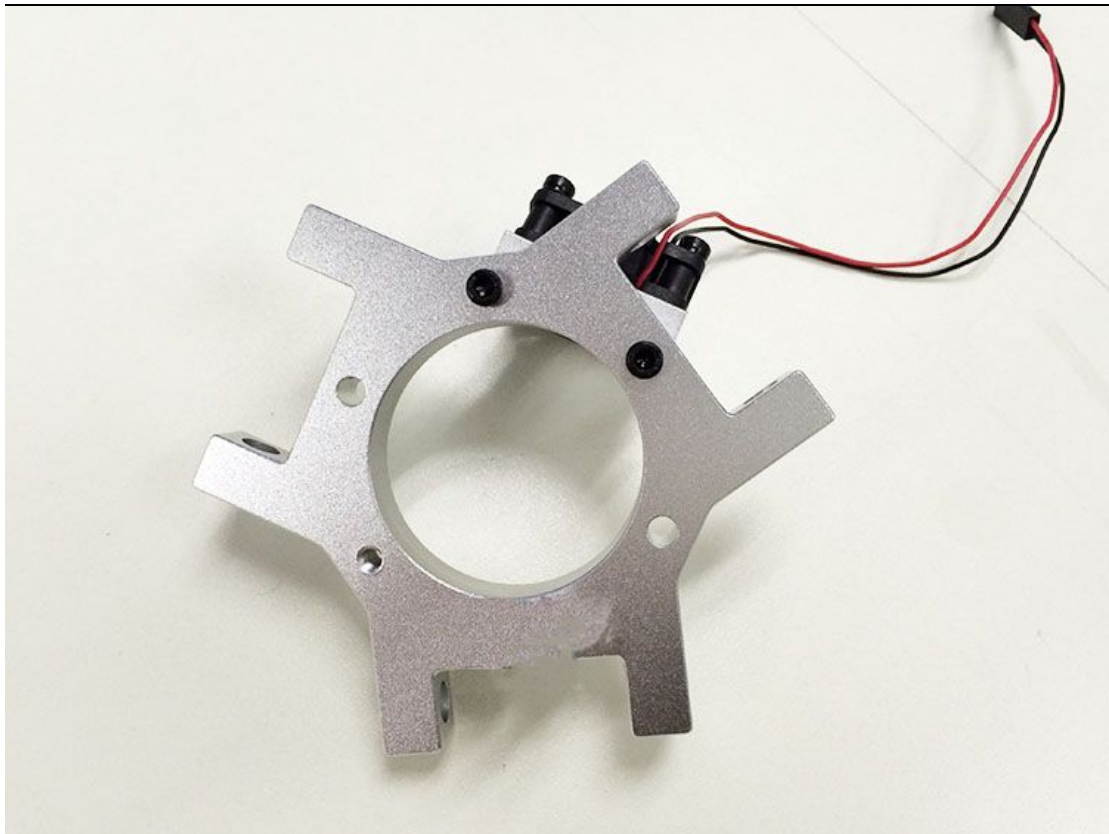

Step2. Mount the assembled fan mount on the spider with 2 M3 x16mm screws.





4.2 Mount the Probe mount

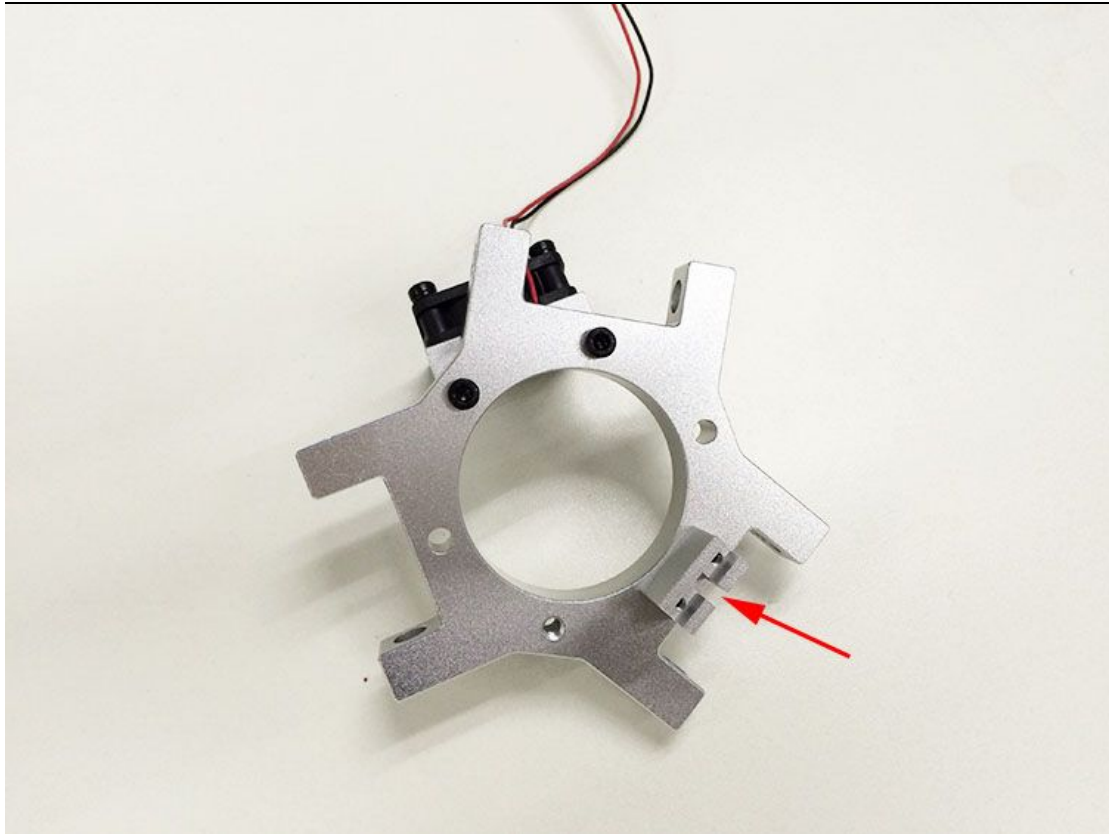

Name	Part NO.	Qty	Pic
Probe mount	NO.M4	1	
M2.5 x 16 screw	NO.17	2	

Mount the Probe mount on the spider with 2 M2.5 x16mm screws from bottom to up.



4.3 Mount the rod-end bearing holder and diagonal rod

Name	Part NO.	Qty	Pic
Diagonal Rod	NO.4	6	
rod-end bearing holder	NO.3	6	
Round head screw with pad	NO.15	6	

M3 washer	NO.5	6	
M3 x 8 screw	NO.18	6	





Step1. Insert the rod-end bearing holder into the diagonal rod joint on the spider, fix it with M3x8mm screw and M3 washer.

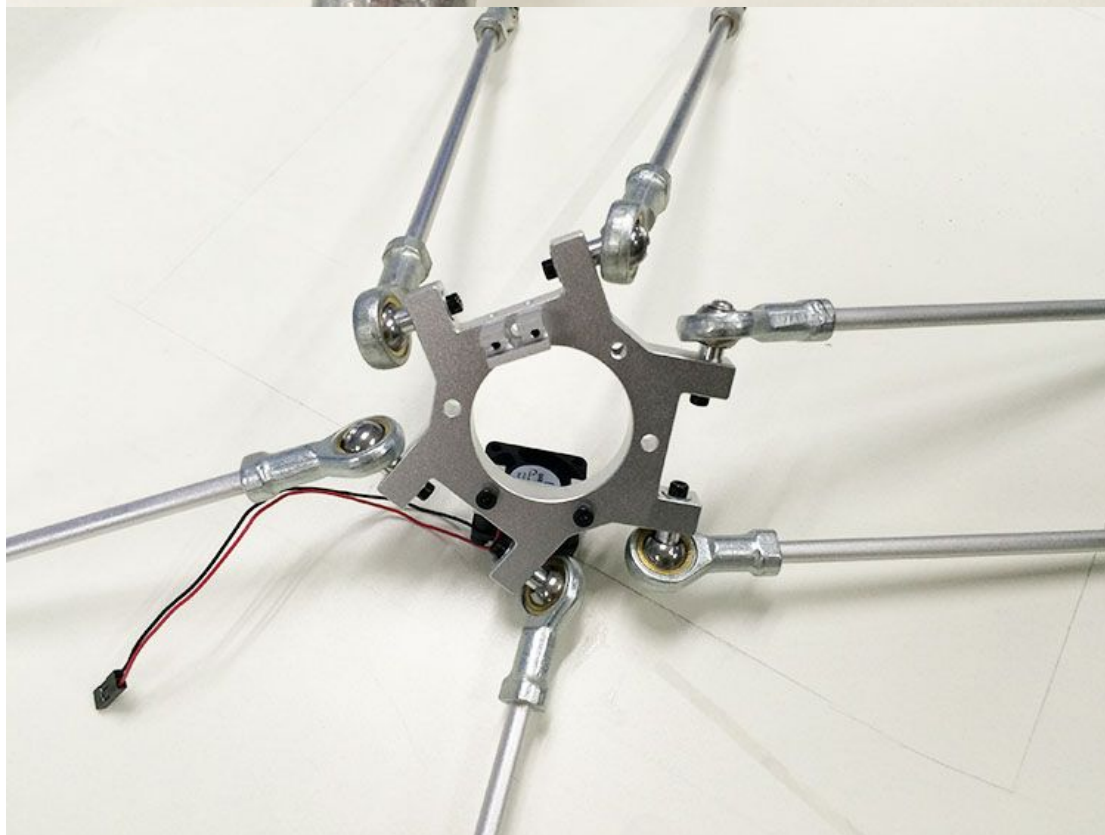
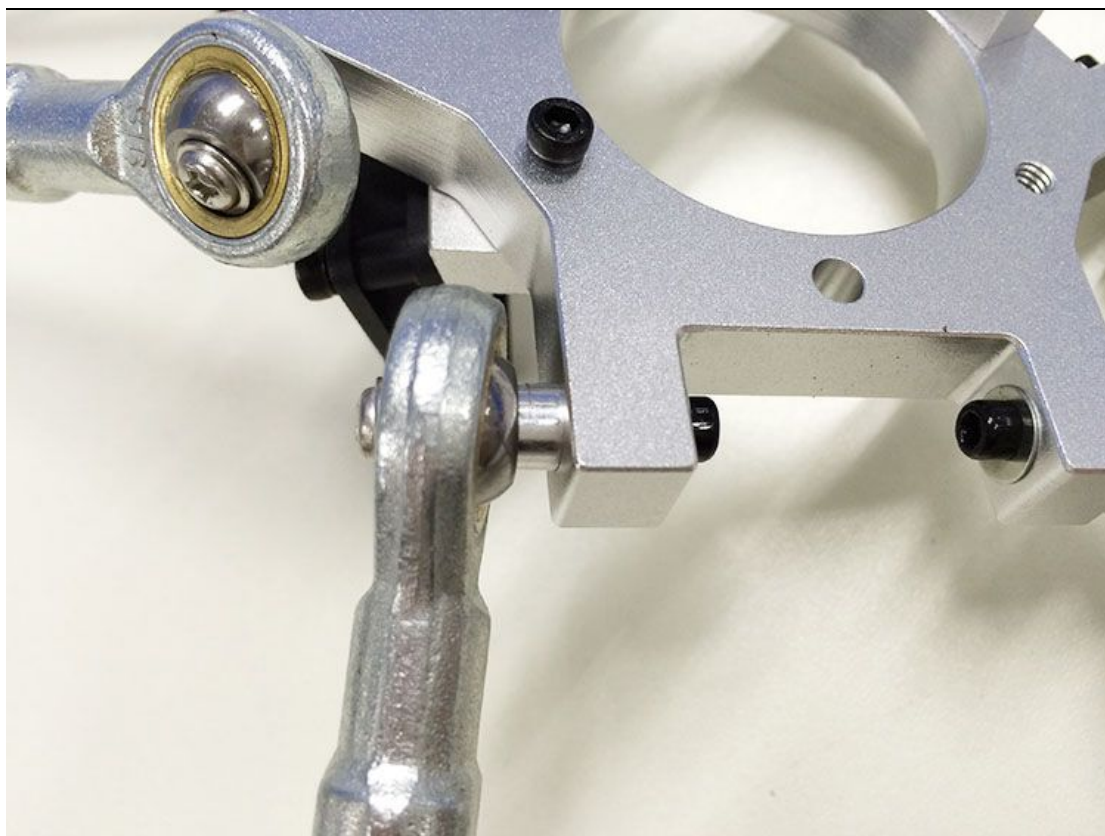

Step2. Fix the Diagonal Rod on the rod-end bearing holder with Round head screw with pad.



4.4. Mount the endstop and the probe.

Name	Part NO.	Qty	Pic
Endstop	NO.44	1	
Probe	NO.43	1	
Spring(3.5*30)	NO.29	1	
Probe Lock ring	NO.M3	1	
M2.5 x 8 screw	NO.16	2	

Step1. Mount the endstop on the spider close to the probe mount with 2 M2.5 x 8 screws.

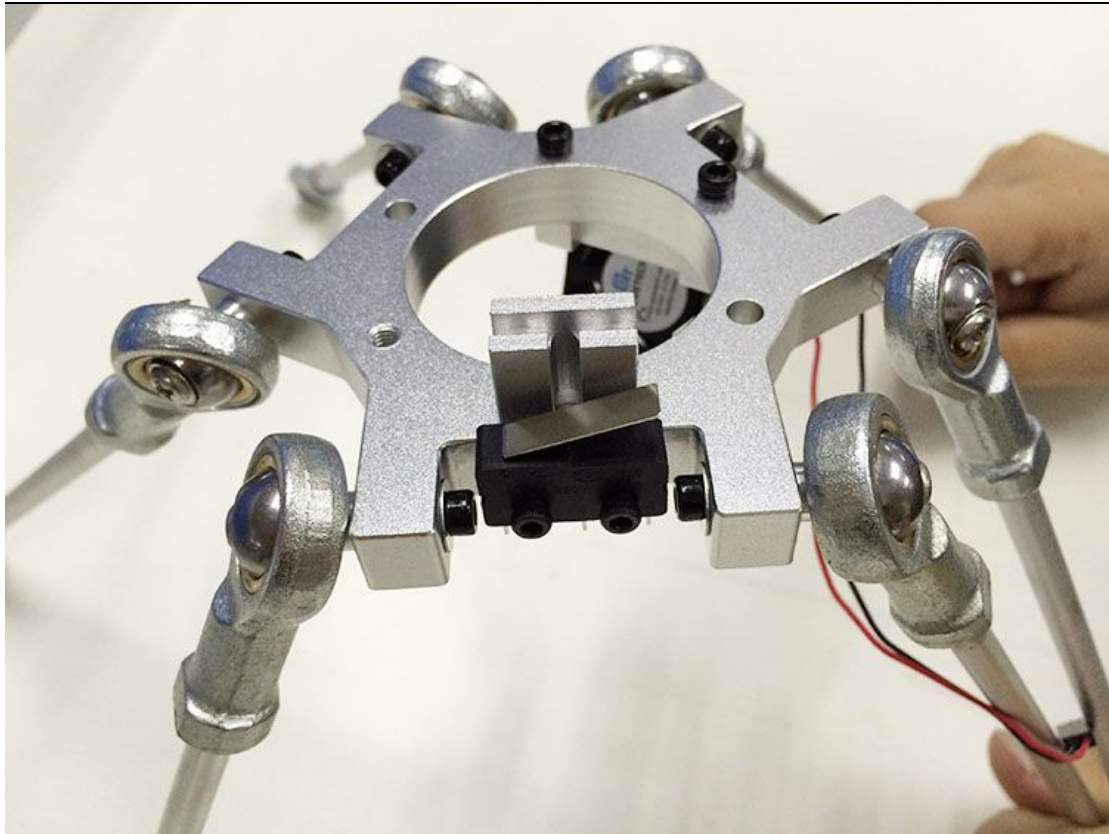

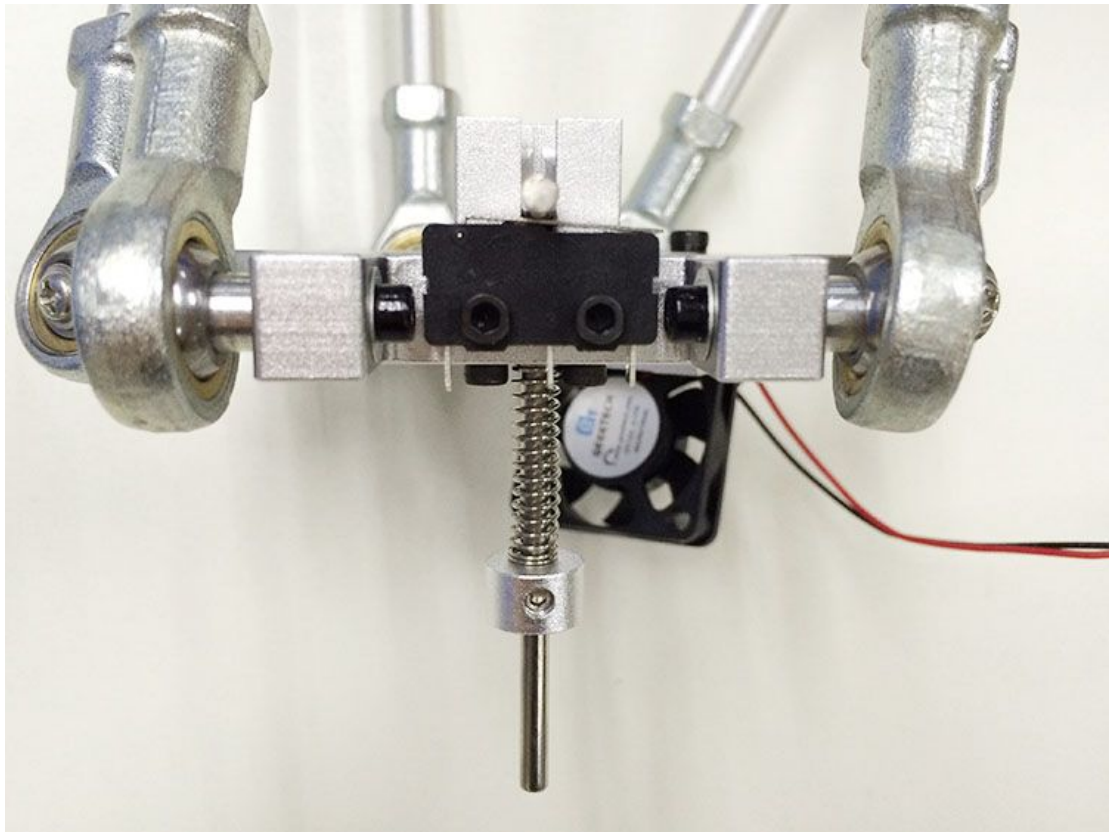

Step2. Put the probe into the probe mount and lock it with a lock ring and spring.

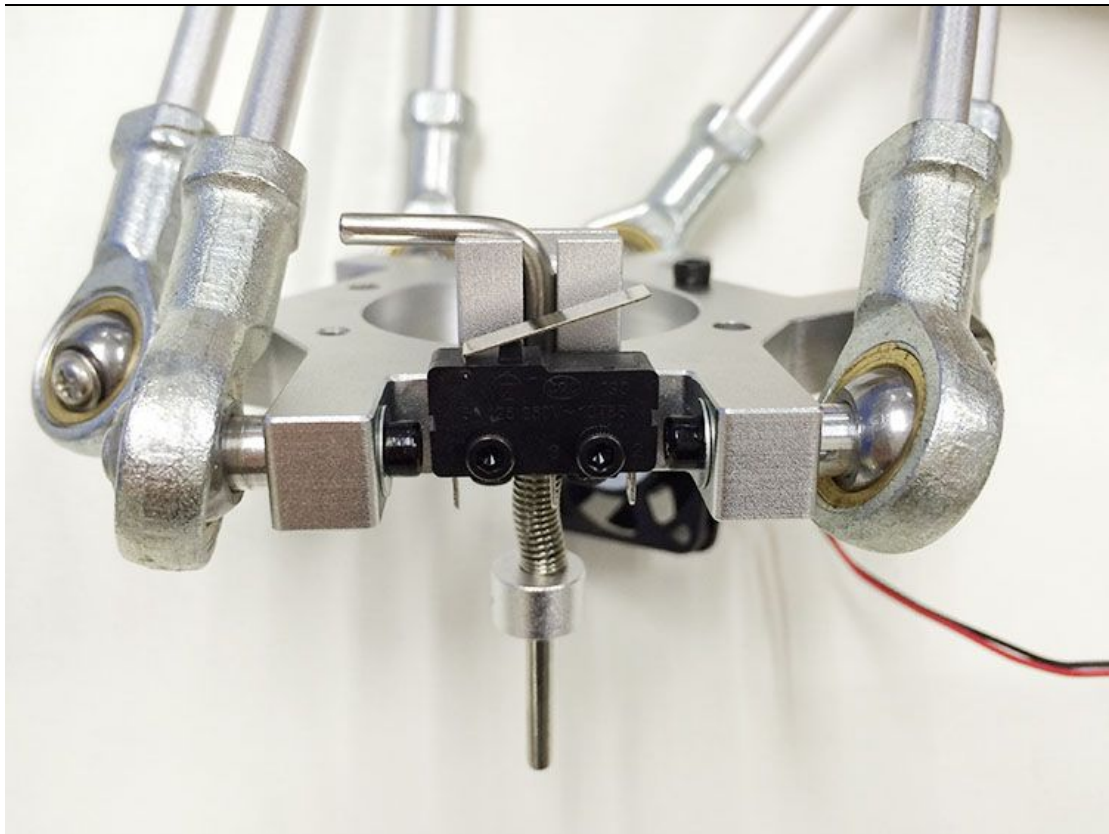



4.5 Mount the hotend.

Name	Part NO.	Qty	Pic
Hotend	NO.57	1	
M4 x 16 screw	NO.25	2	



Mount the hotend on the spider with 2 M4 x 16 screws.

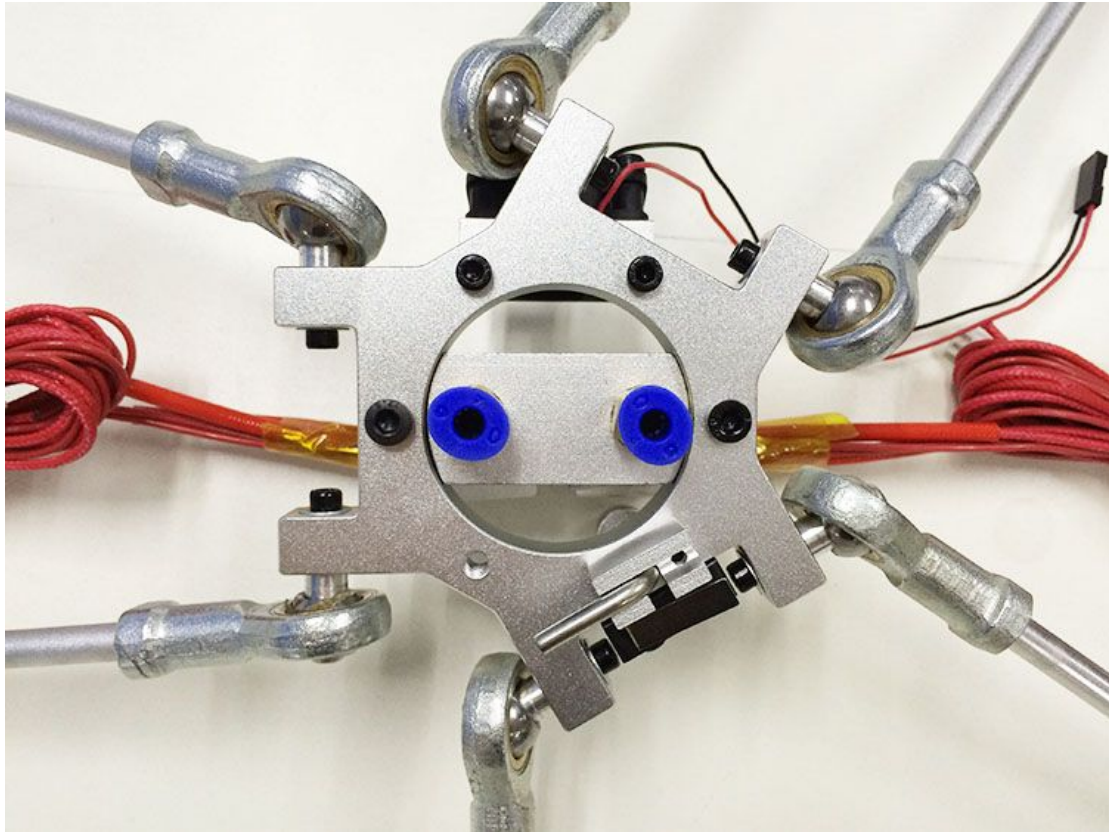

For the single hotend, use the same way to mount.



[Videos](#)

5 Mount the smooth rods

Name	Part NO.	qty	Pic
Smooth Rod	NO.1	6	
M4 x 8 Screw	NO.24	6	

M8 Washers	NO.8	6	
M4 washer	NO.6	6	

Step1. Put a M8 washer on the end of the smooth rod. Insert the rods into the holes on the base plate;

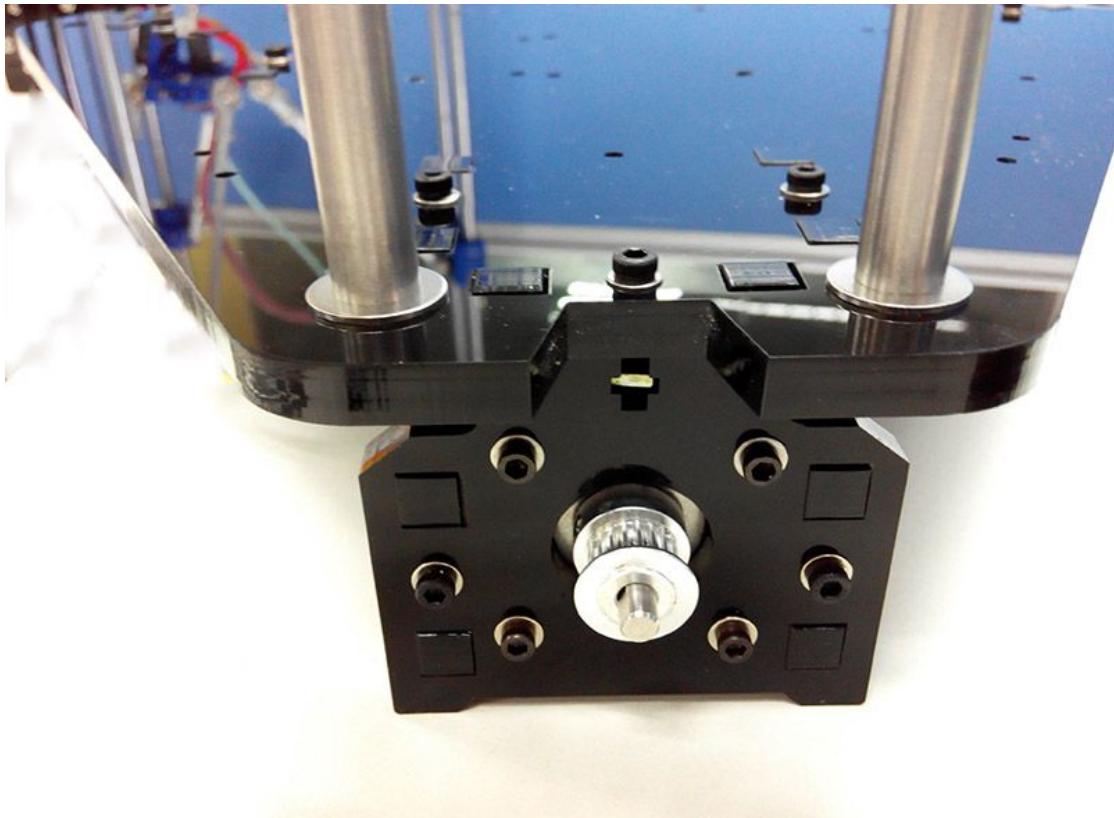

Step2. Screw up the rods with M4x8 screws and M4 washers.

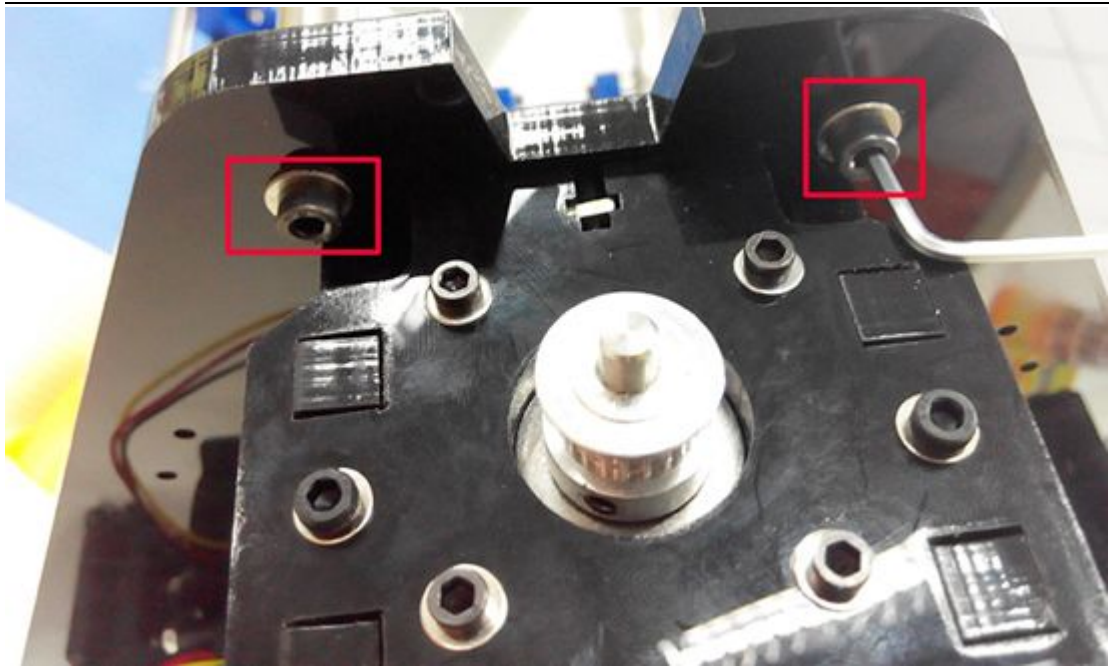



Repeat the above two steps for other 5 rods.



[Videos](#)

6 Mount the carriage and the top plate

Name	Part NO.	qty	Pic
M4 x 8 Screw	NO.24	6	
M8 Washers	NO.8	6	
			

M4 washer	NO.6	6	
-----------	------	---	--

Step1 Slide carriages onto the 6 smooth rods separately.

Note:

*When you do this, you'd better take the top plate here to check if the long screw on the carriage will hit on the opening of the endstop when the carriages raised up.

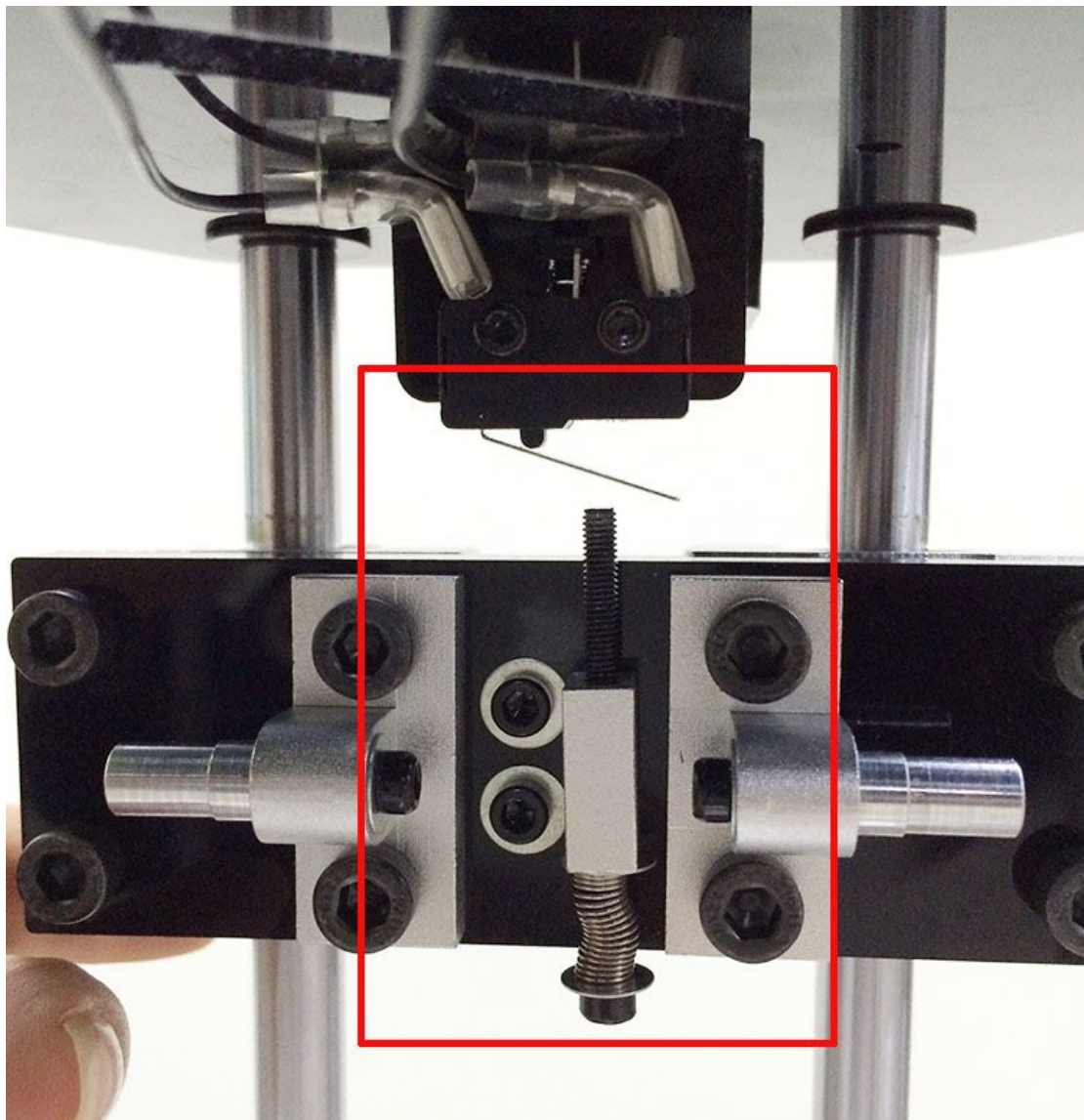

* If you find it difficult to slide the carriage to the rod, or it cannot slide smoothly,

you can loose the screws on the linear bearings a bit.

Step2. Put a M8 washer on each top end of the rods and cover the top plate on the rods, screw them up with M4x 8mm screws and M4 washers.



In some instances, the smooth rods' M4x 8mm end threads are too shallow by a few mm, due to variation of manufacture.









In this case, you will be unable to fully tighten the M4x 8mm bolts into the rods.

If this occurs, use the spare M4 washers bridge the gap.

[Videos](#)

7 Mount the Belt

7.1 Assemble the driving wheel

Part name	Part NO.	Required number	pic
Driven wheel holder	NO..33	3	
Driven wheel	NO..32	3	
R84zz Ball Bearing	NO..31	6	
M3 x16mm screw	NO..20	3	
M4 x 25mm screw	NO..26	3	
M4 washer	NO..6	3	
M4 lock nut	NO..11	3	
wing nut	NO..12	3	

Step1. Thread the M3 x 16 screw through the Driven wheel holder.

It is of critical importance to fully tighten the bolt in the middle of the sheet metal U holder for the idler pulley.

If the bolt is not fully tightened, when the wing nut is used to secure the pulley, it can cause the bolt to back out slightly, and press against the belt. This can then cause the belt to jam, and cause a head crash.



Step2. Insert the two MR84zz ball bearings into both ends of the driven wheel.

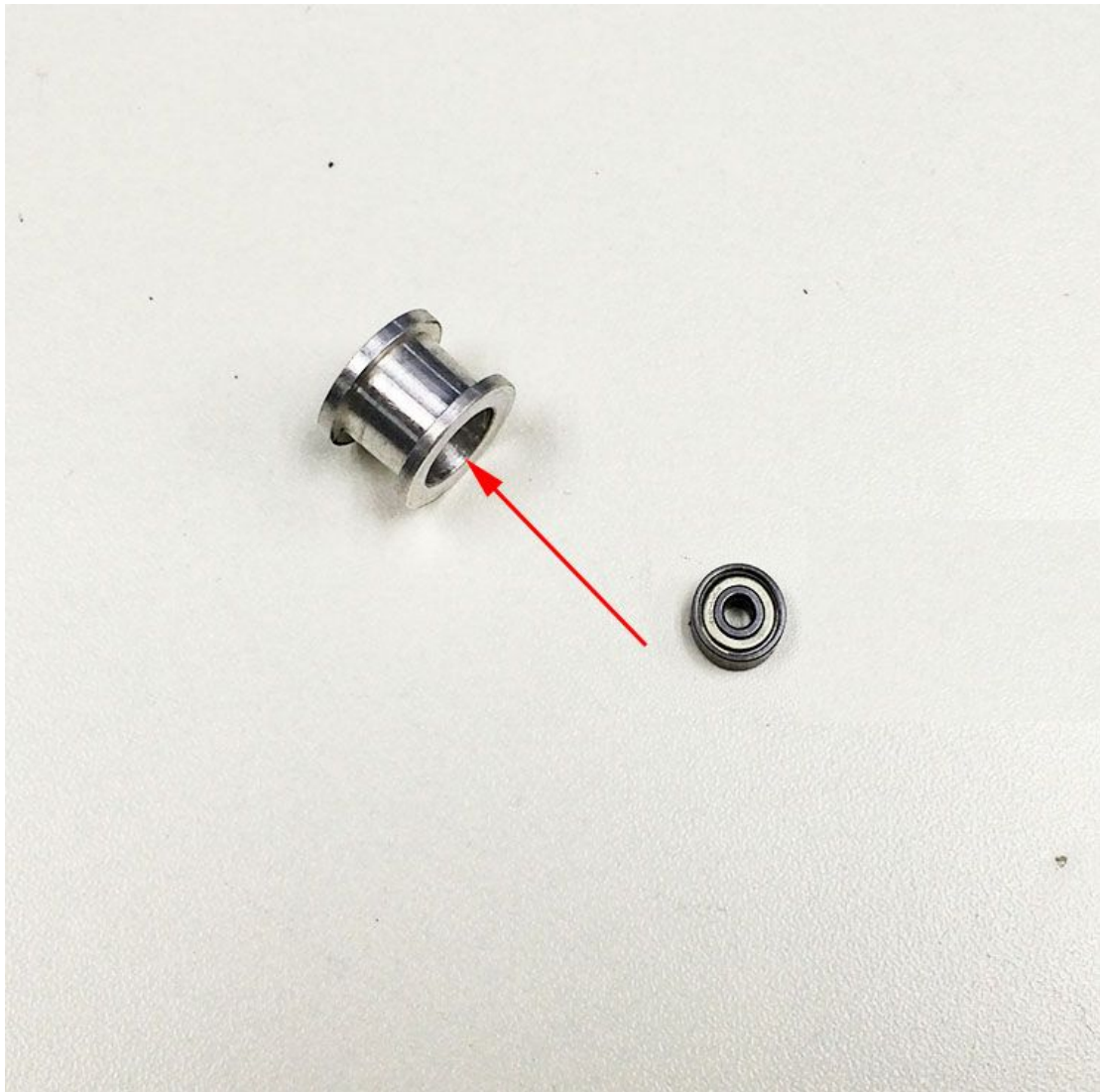





Step3.Put the M4 x25 screw and M4 washer through the driving wheel. Lock the other end with a M4 lock nut. You may need a wrench to tighten locking nut.





*Do not screw it too tight, you should leave enough room for the wheel to turn freely.
Repeat the steps for the other 2 driven wheel.

7.2 Add the belt

Name	Part NO.	Qty	Pic
Timing Belt	NO.36	3	
M3 x8 Screw	NO.18	6	
M3 washer	NO.5	6	

Step1. Thread the belt through the driven wheel end. And fix the driven wheel loosely

on the top plate with a wing nut.

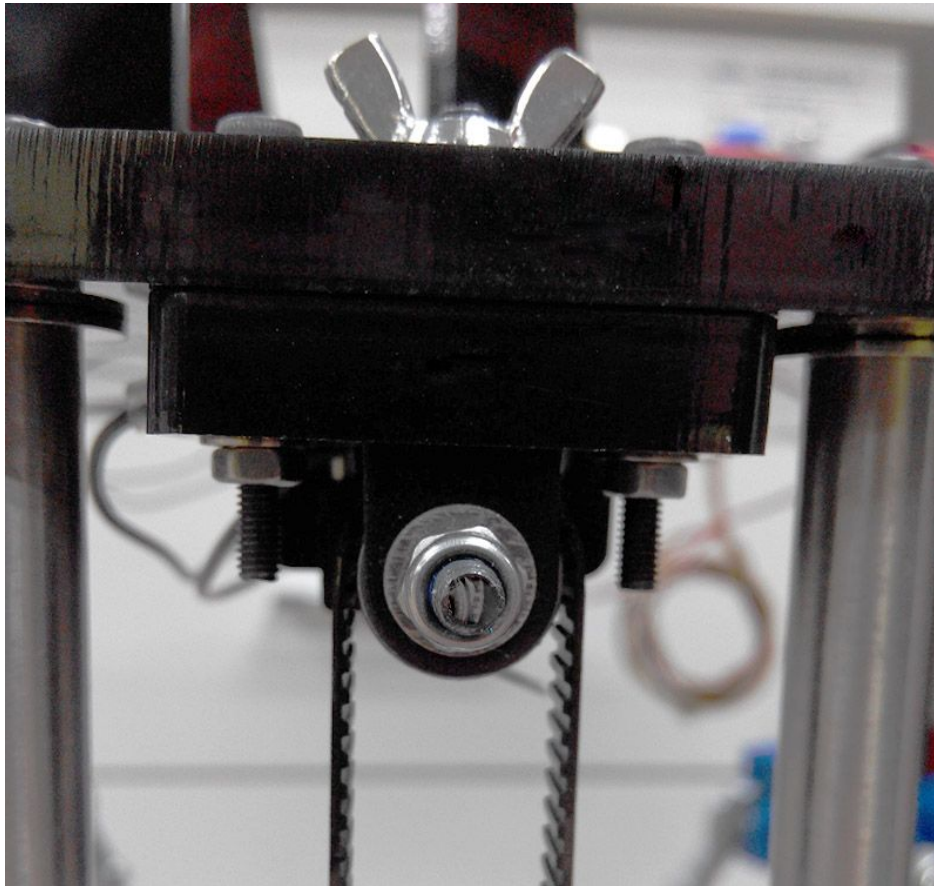

Step2. Fix one end of the belt on the belt mount with a M3x8mm screw and M3 washer.

Step3 Pull down another end of the belt to the pulley.

Twist the the belt around the pulley, taut the belt to the other end of the belt mount.
fix it with a M3x8mm screw and M3 washer.

*Before you cut the belt, be sure you are sure about the length, it is about 110cm.

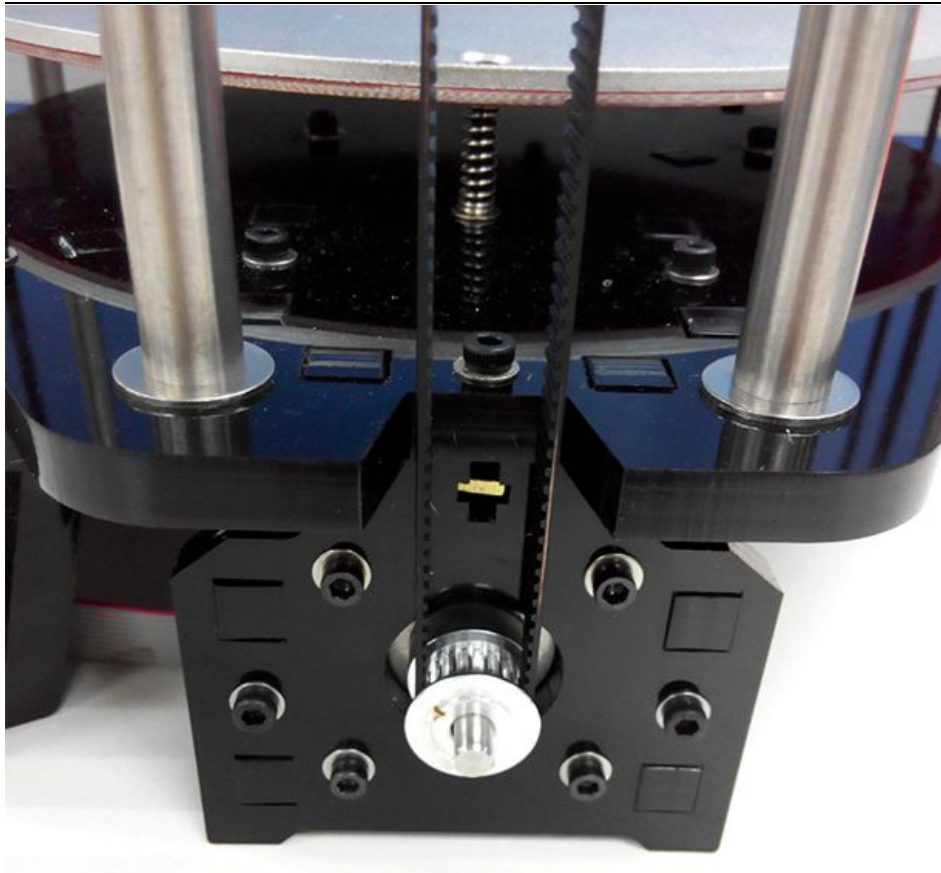

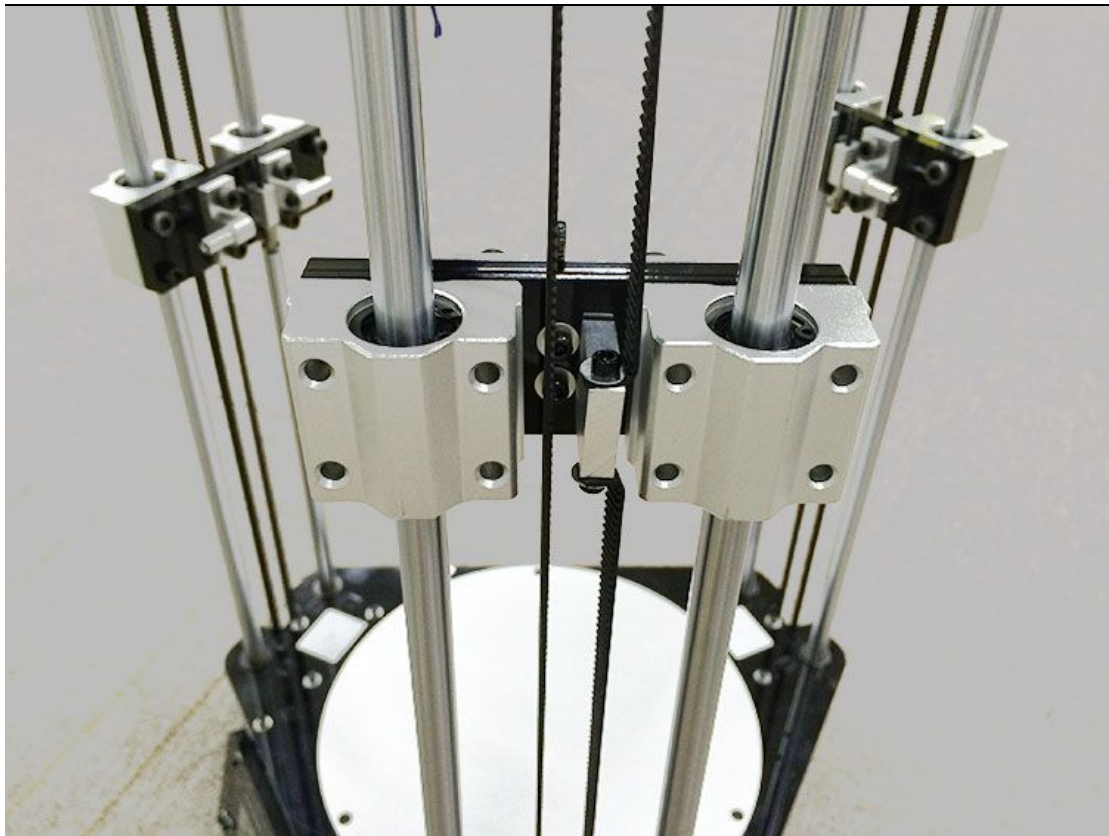

Step4 Tighten the wing nut to taut the belt. The wing nut must be fully tightened, or the sheet metal holder can 'lean' slightly, and cause the belt to jam against the pulley holder.

Adjust belt tension by loosening the wing nut, changing the belt notch that is held by the carriage belt retainer, then fully tightening the wing nut.

Repeat the above steps for the other 2 belts.

[Videos](#)



8 Connect the Diagonal Rod to the carriage

Name	Part NO.	Qty	Pic

Round head screw with pad	NO.15	6	
---------------------------	-------	---	---

Connect the Diagonal Rod on the assembled print platform to the carriage.

Fix the Diagonal Rod on the rod-end bearing holder with Round head screw with pad.

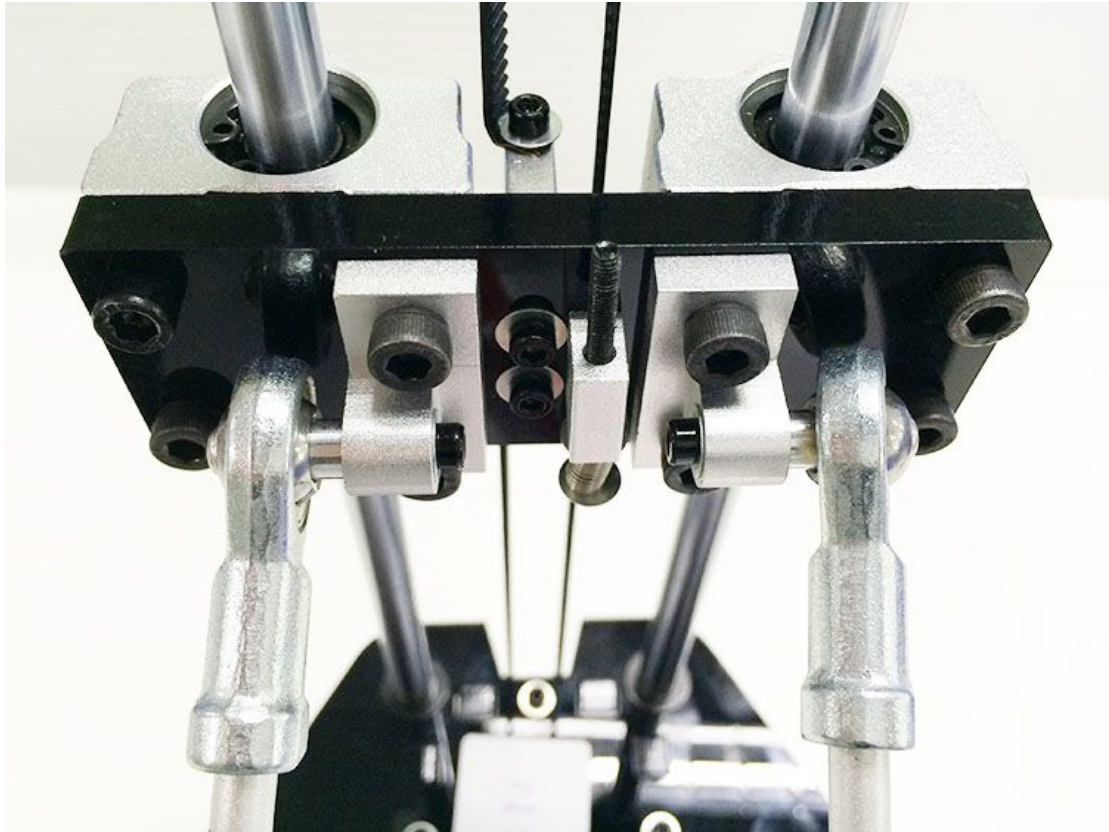

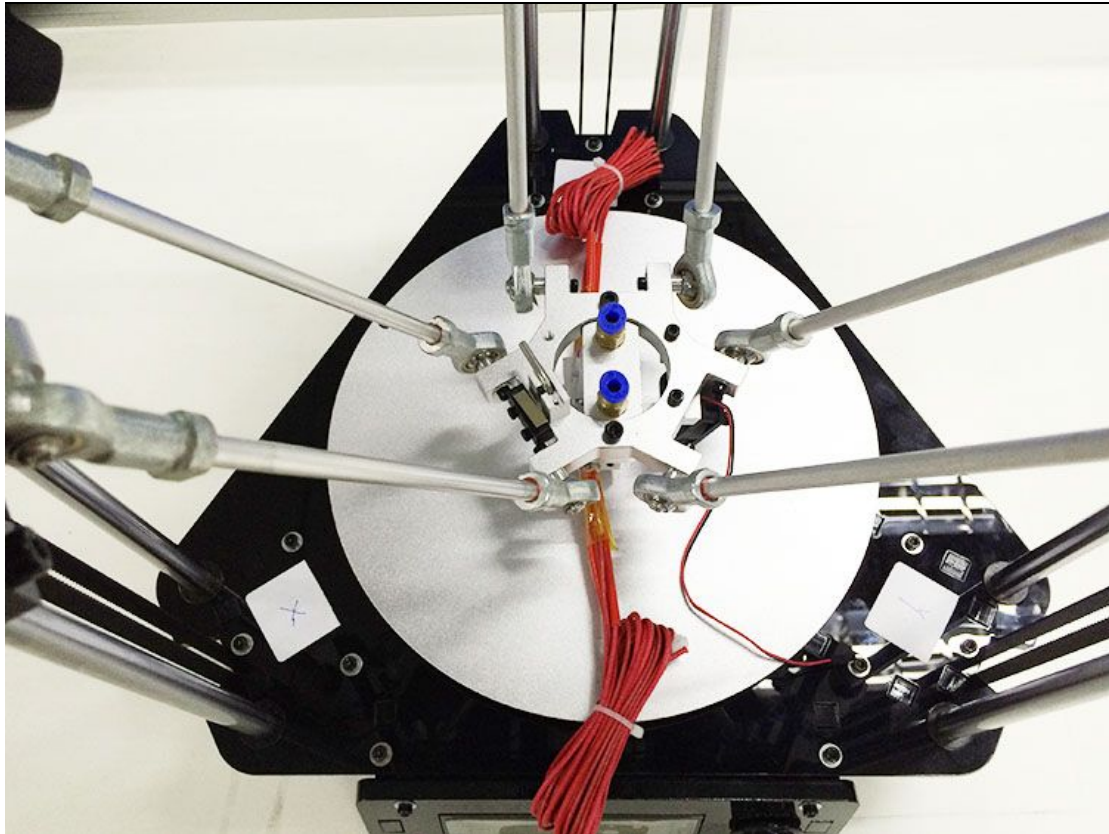

***Note. The auto-leveling device is towards the X tower, as shown in the picture.**



[Videos](#)

9 Mount the extruder

Lets take the dual extruder as example.

Name	Part NO.	Qty	Pic
Extruder	NO.56A&B	2	
M5 x 16 screw	NO.27	8	

--	--	--	--

Find out the locating holes on the top plate; screw up the extruder with 8 M5 x 16 screws and washers from bottom to up.

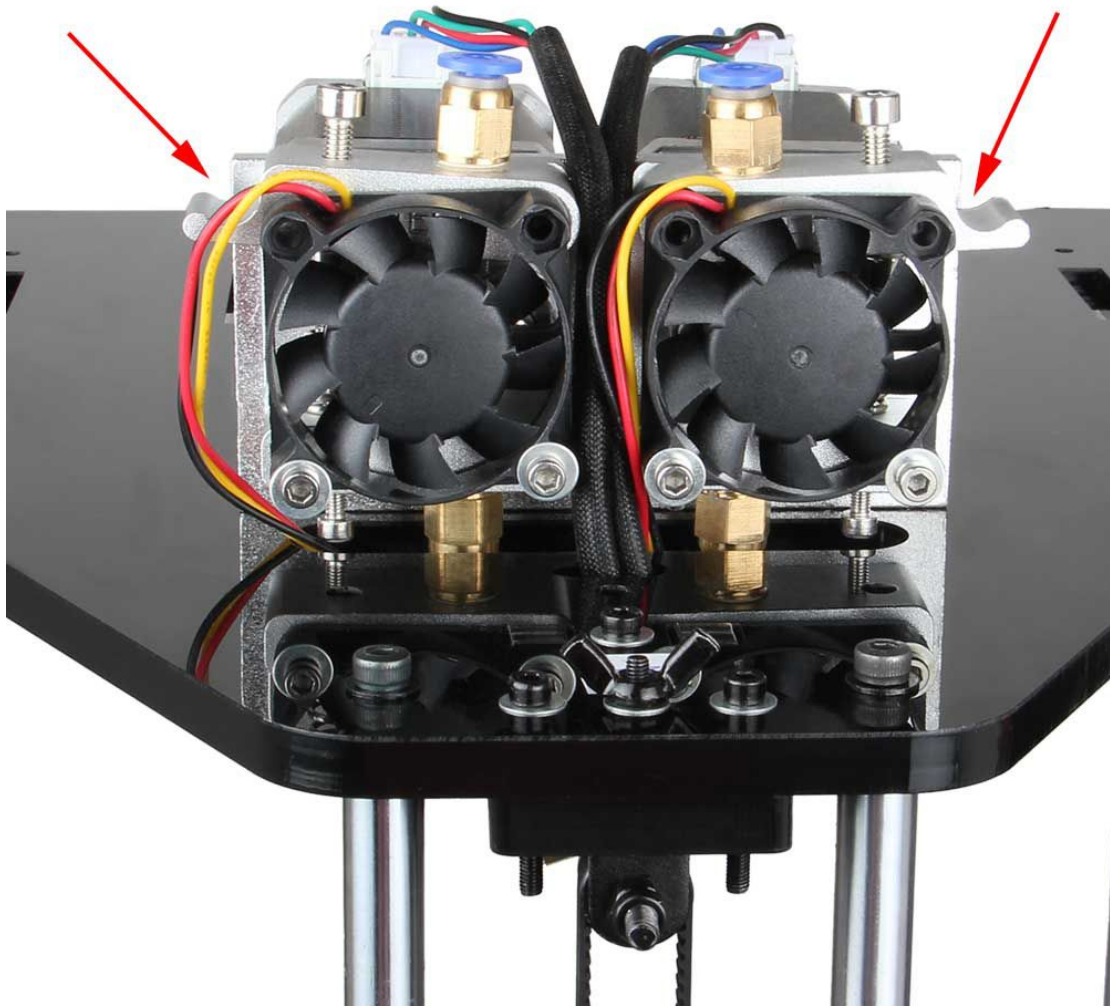

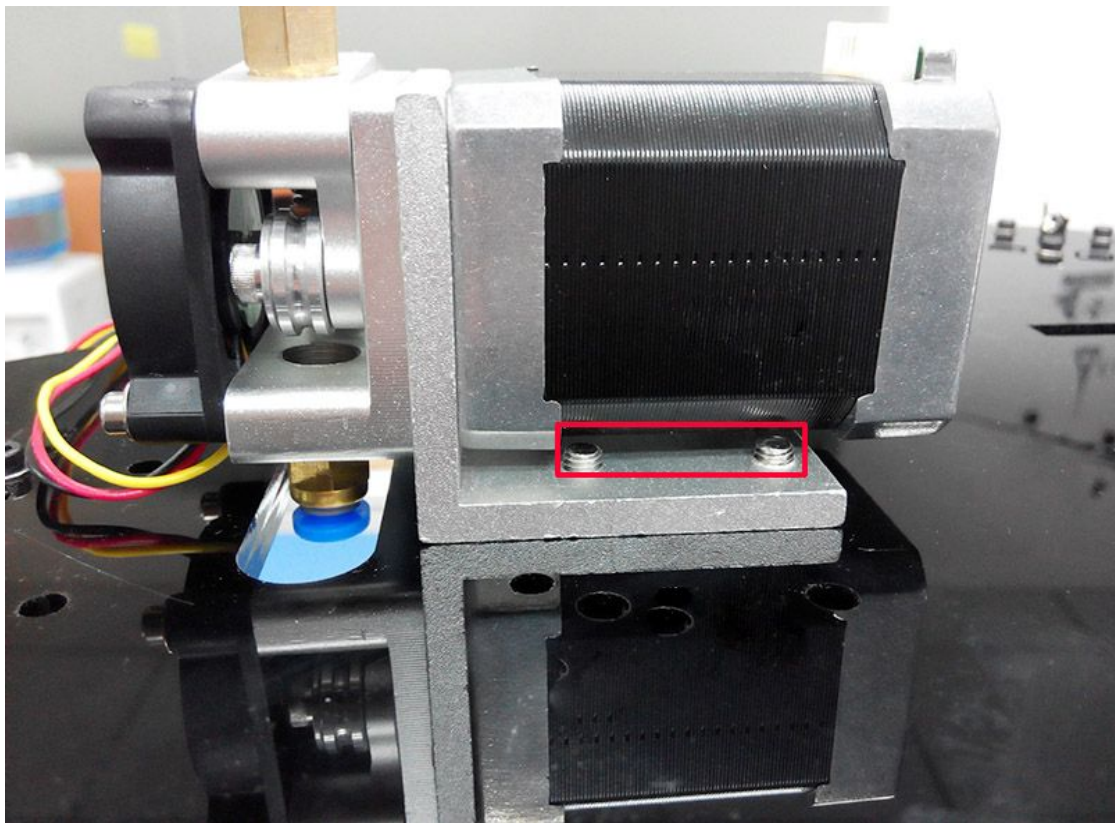





[Videos](#)

10 Mount the filament holder

This step can also be finished at last if you like.

Name	Part NO.	Qty	Pic
Spool holder Side panel	NO.A10	1	
Spool holder Side panel	NO.A11	1	

M3x16 screw	NO.20	4	
Square nut	NO.13	4	
locking ring	NO.30	2	

Screw up A10 and A11 on the top plate separately with M3x16 screw,M3 square nut and washer.

EXAMPLE 1: G2



EXAMPLE 2: G2S



For this dual filament spool, you need to use the locking ring to lock the spool on both end.

[Videos](#)

11 Connect the feeding pipe

Name	Part NO.	Qty	Pic
Feeding pipe	1	1	

Step1. Plug one end of the tube into the push-fitting on the hotend and the other end into that of the extruder.

Before connecting the pipe, you need to match the extruder and the hotend:

The positive extruder is referred to as no.1

The reversed extruder is no.2,

And you are advised to label the wire connector as E1/E2 to distinguish them.

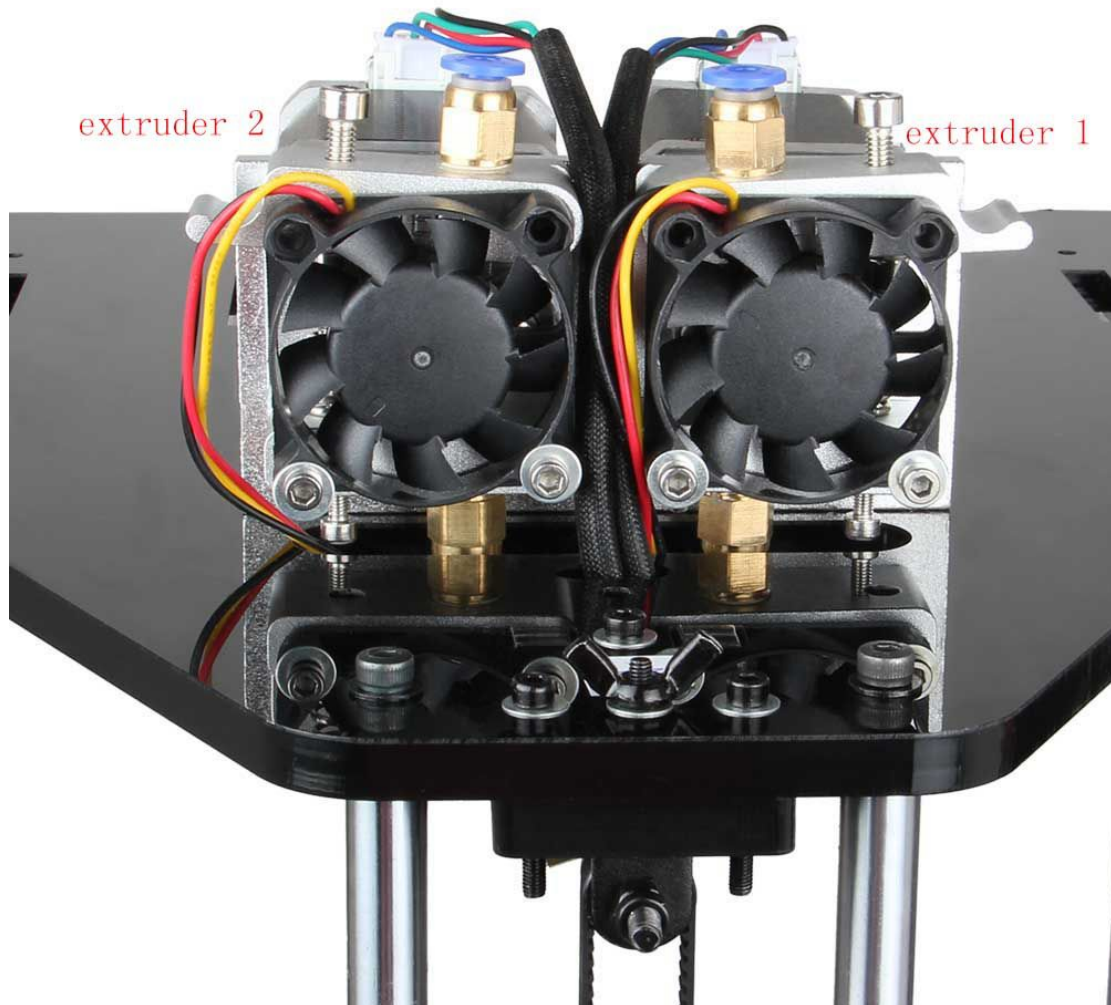

The hotend in front (near the LCD panel) is for extruder1 and the one at behind is for extruder 2.

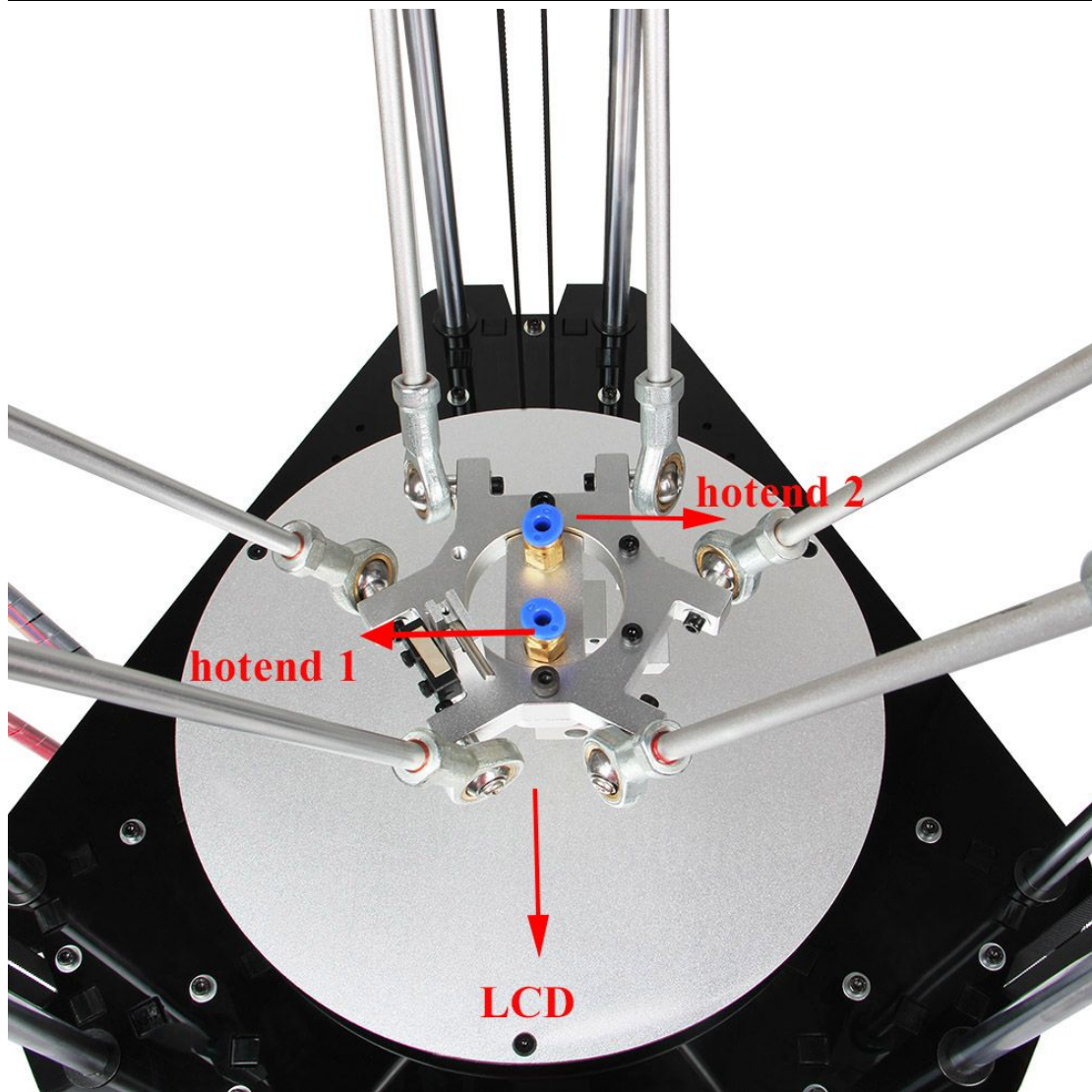

* If you need to pull the tube out, please press the blue part while pulling.

12 Wiring

Before you start wiring, please take a look at the wiring schematics.

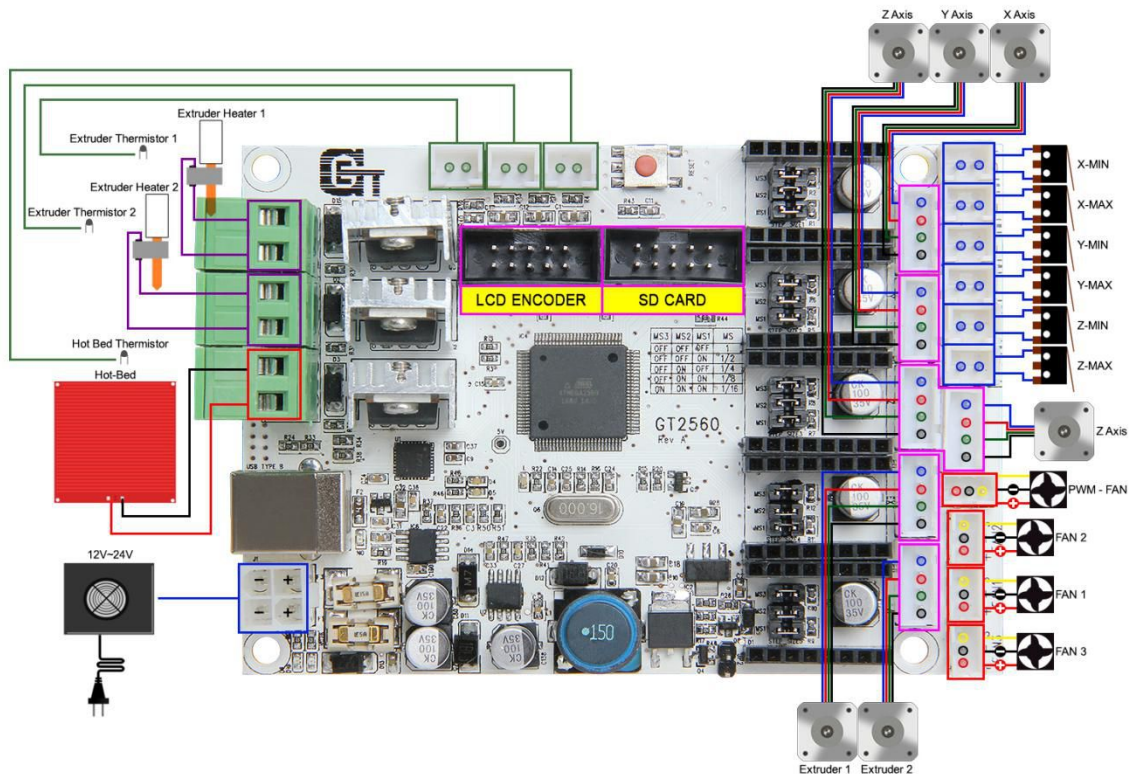

You can see original picture [here](#).

Step1. Connect wires for motors.

- 1) Connect wires for X-axis motor.

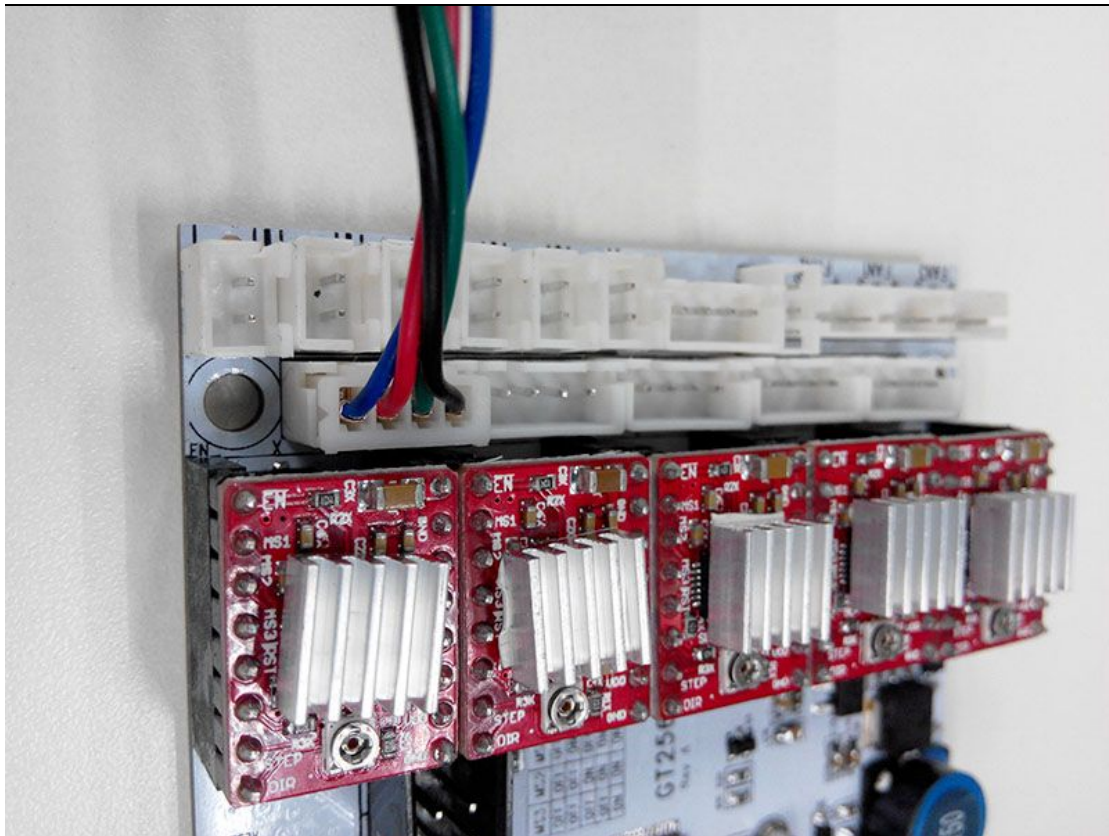

2) Connect wires for Y-axis motor.

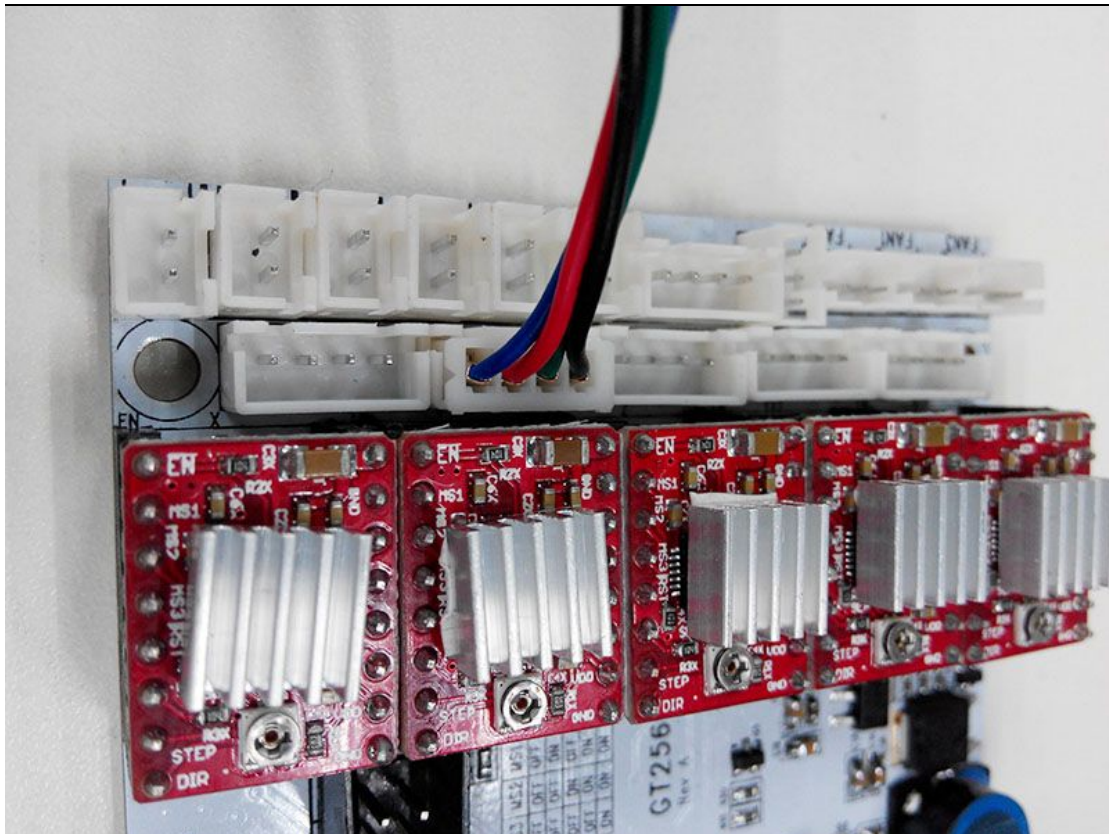

3) Connect wires for Z-axis motor.

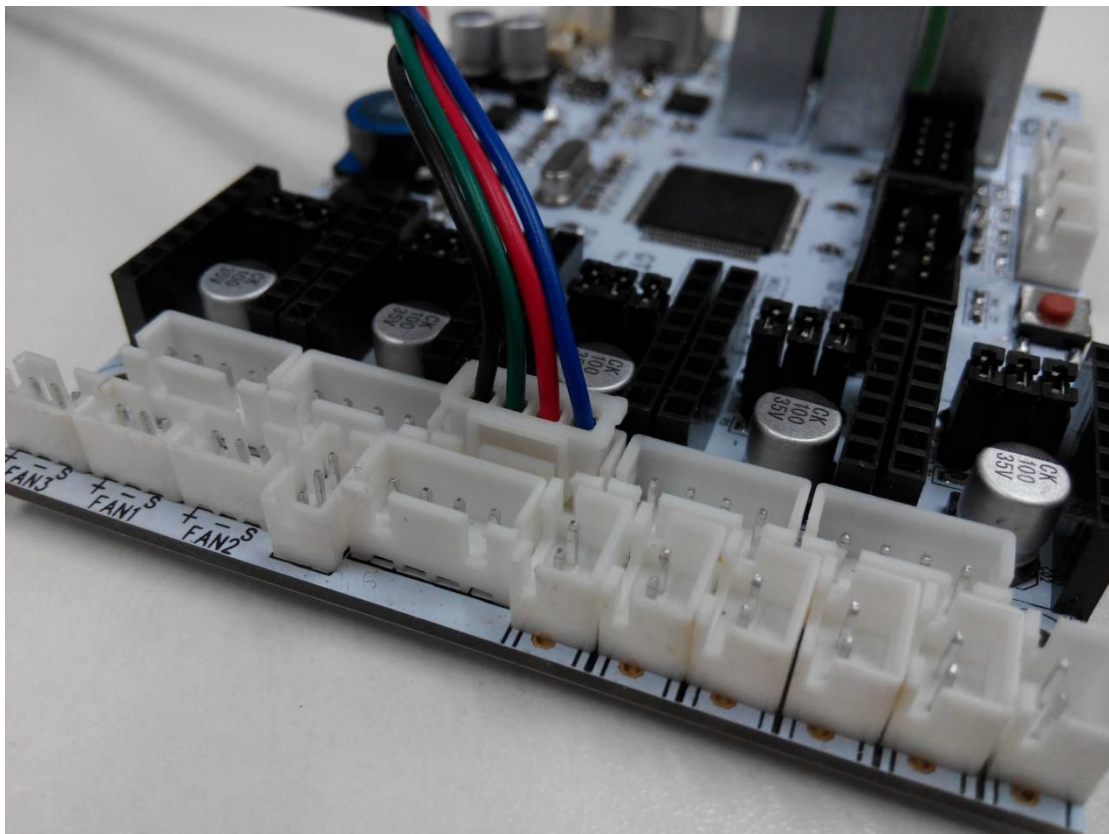

4) Connect extruder motor on either Extruder 1 or 2 for G2; connect on both for G2s.

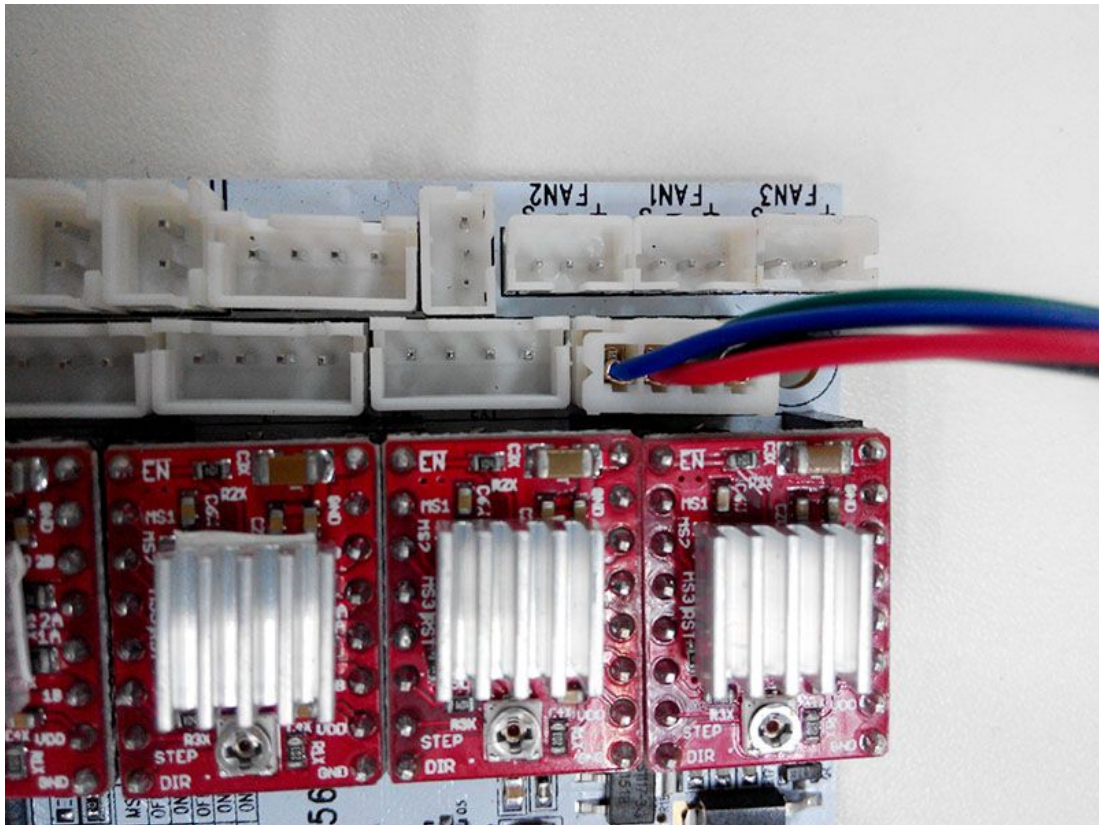
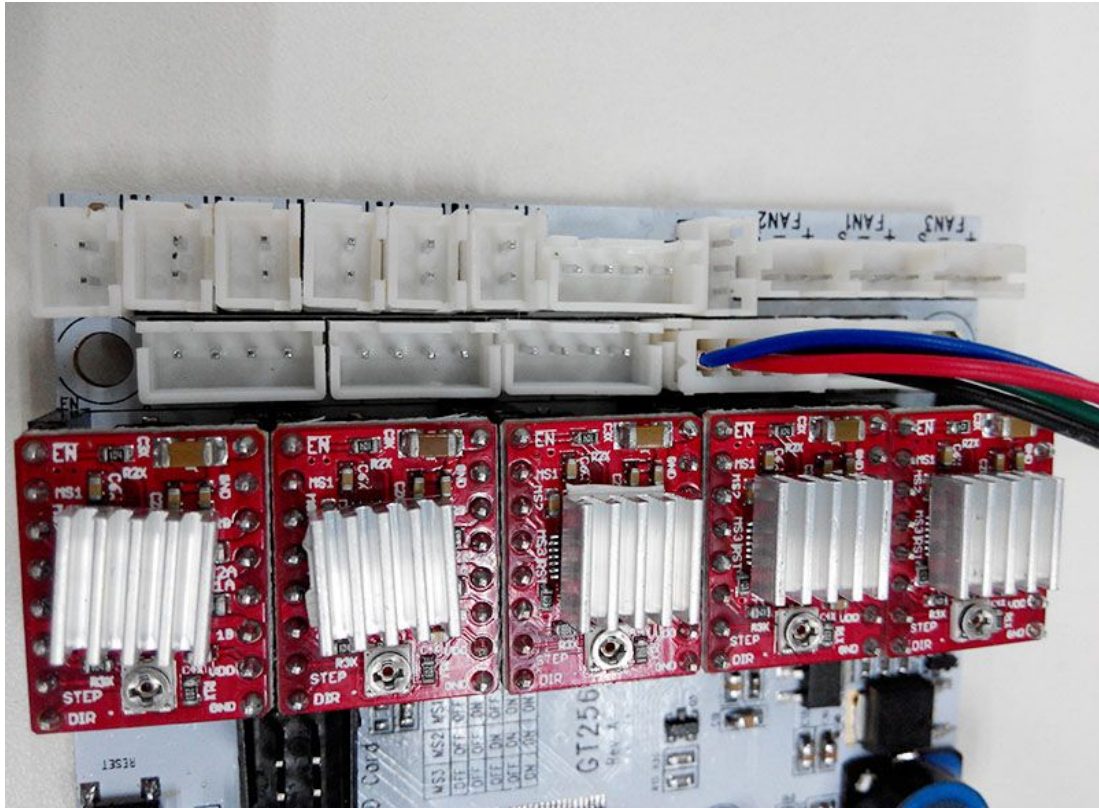

Step4. Connect heating wires.

Loosed the screws in the green terminal and put the red wires into the slot and screw it up.

* There is no “+” and “-“for heating wires

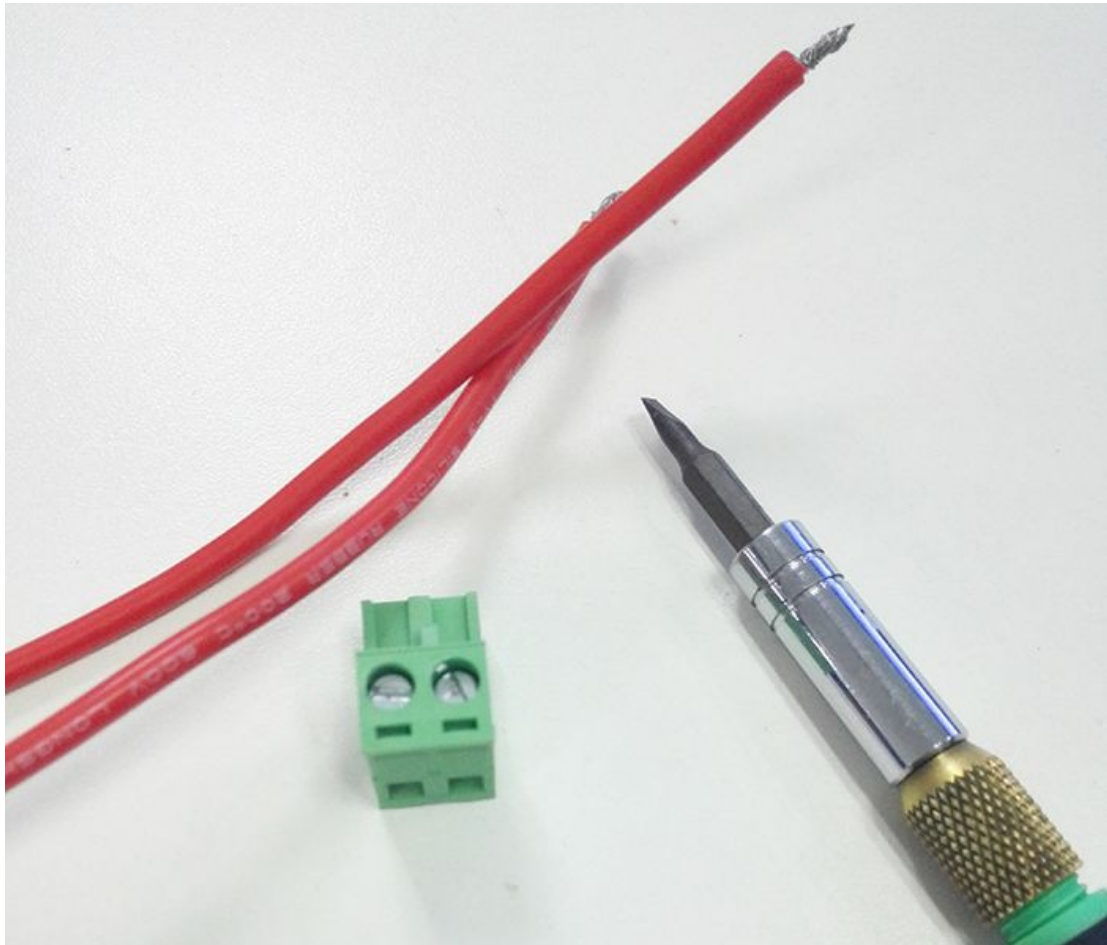

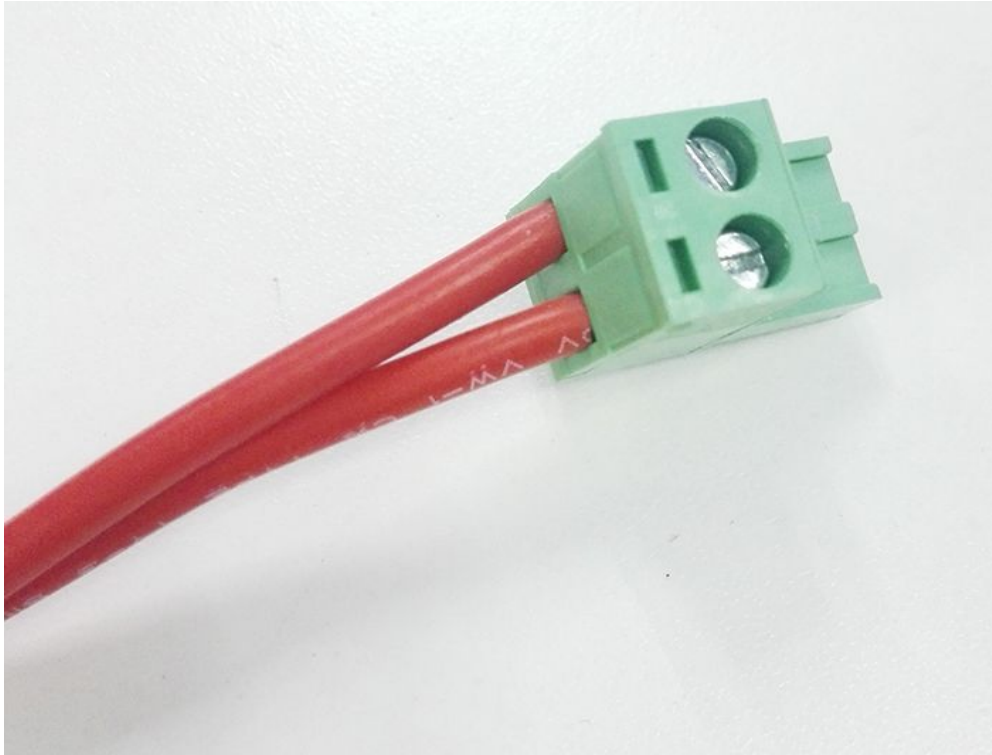

1) Connect heating wires for heatbed.

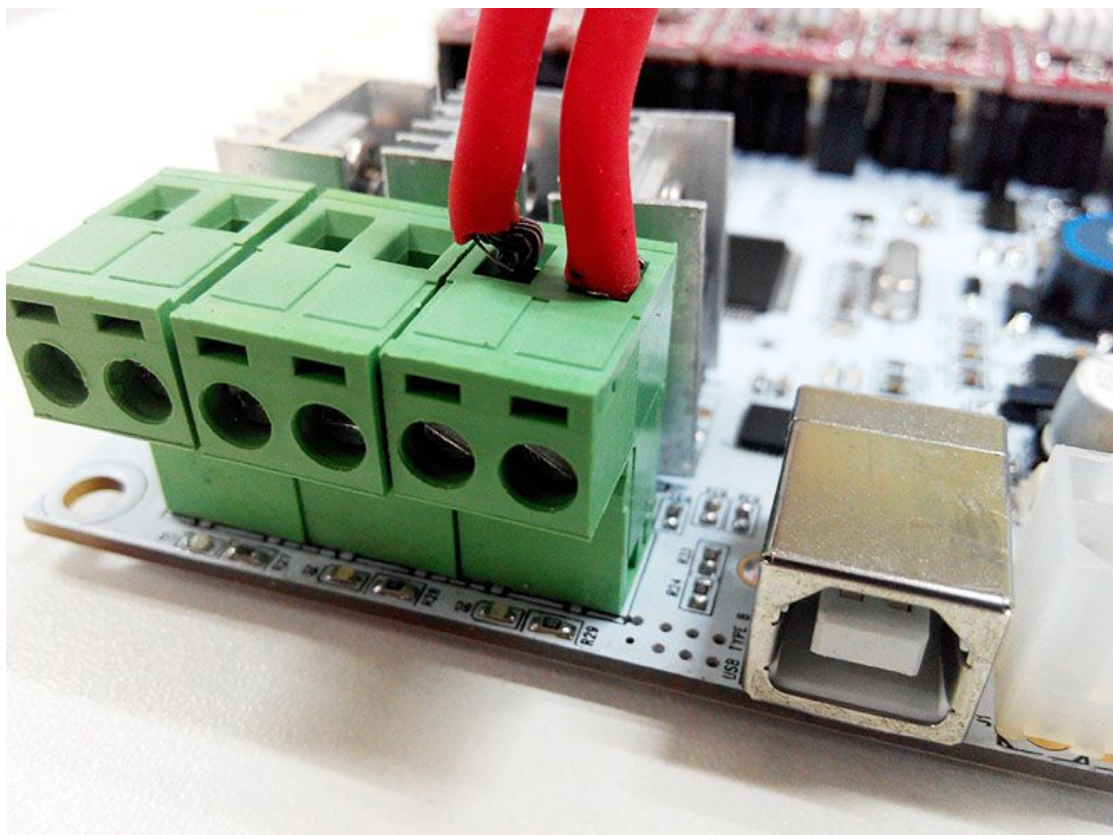

- 2) Connect heating wires for extruder 1. The wires are on hotend 1.

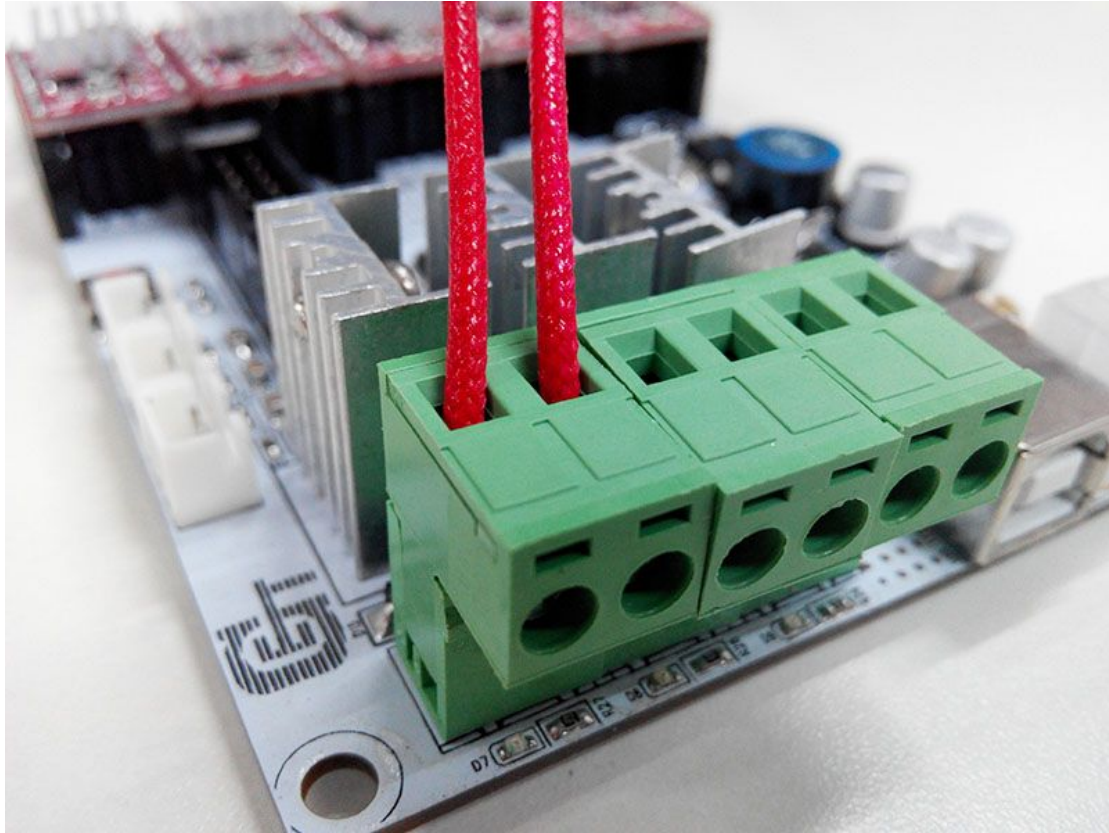

- 3) Connect heating wires for extruder 2. The wires are on hotend 2.

when connecting the wires, you need to pay attention to the correspondence of the wires. Do not mix them up, especially the wires for heating and thermistor.

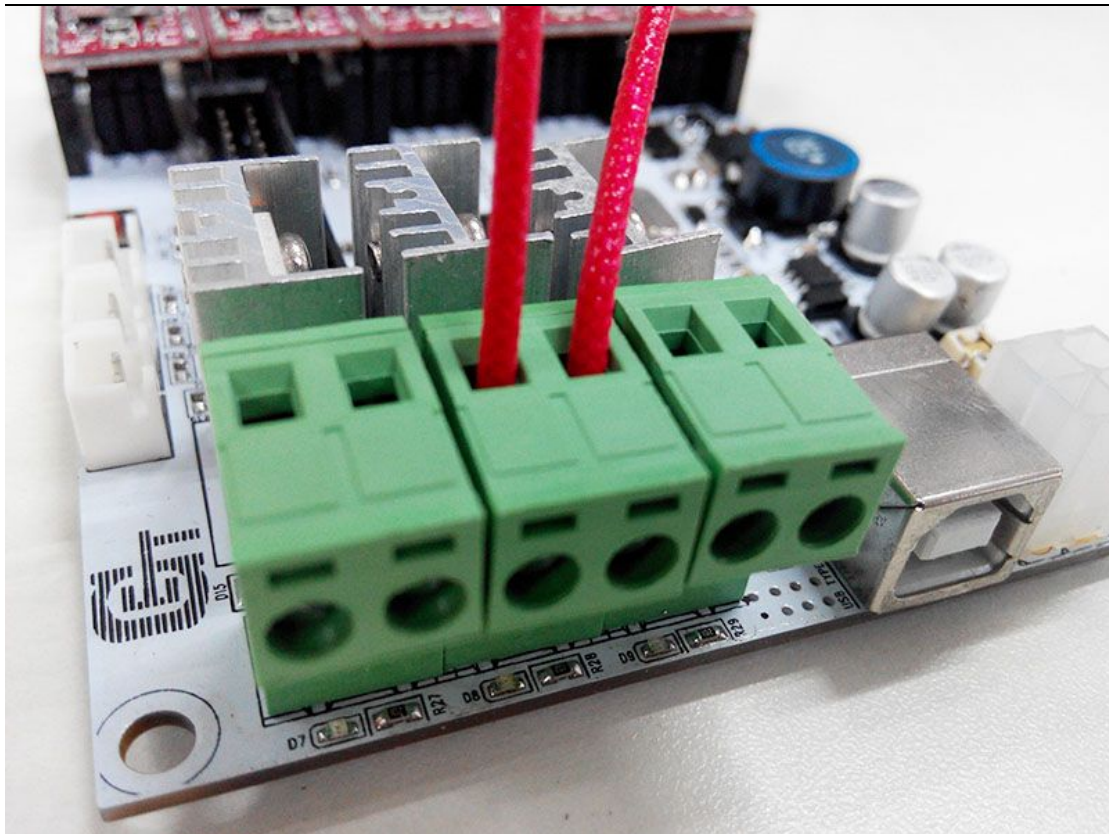

Step4. Connect wires for thermistor.

- 1) Connect wires for thermistor of heatbed.

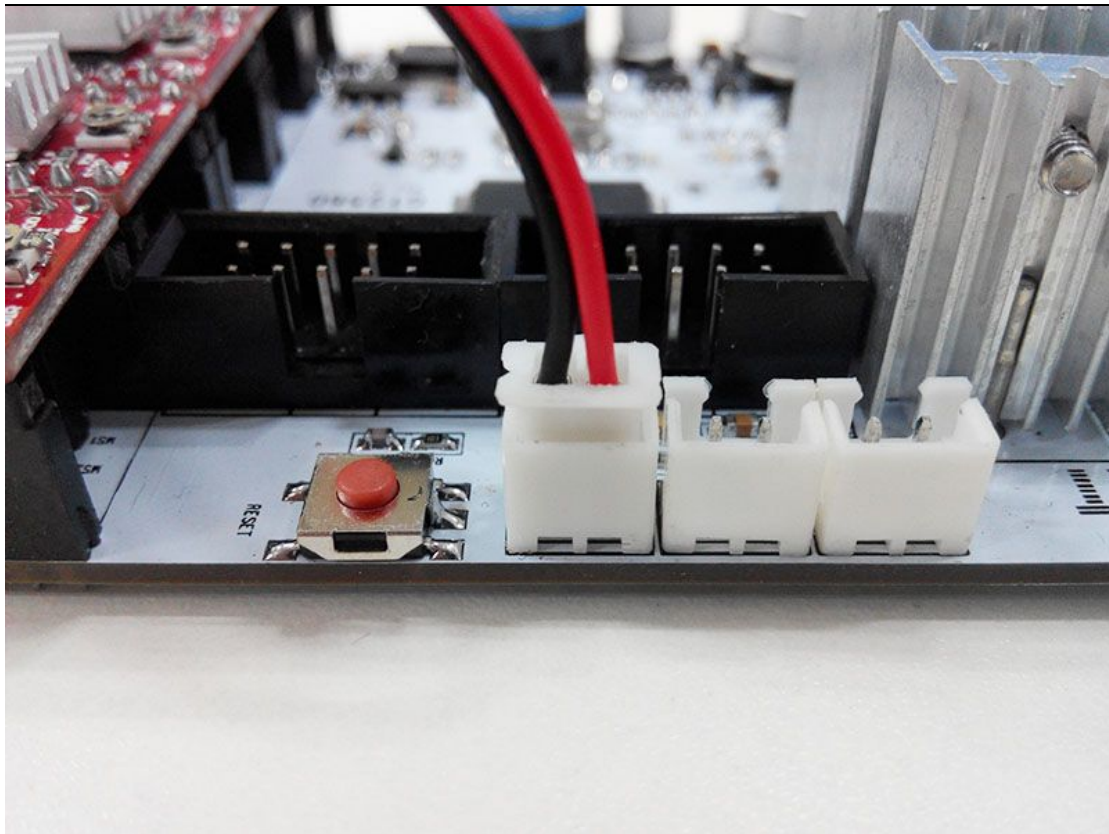

2) Connect wires for thermistor of extruder 1. The wires are on hotend 1.

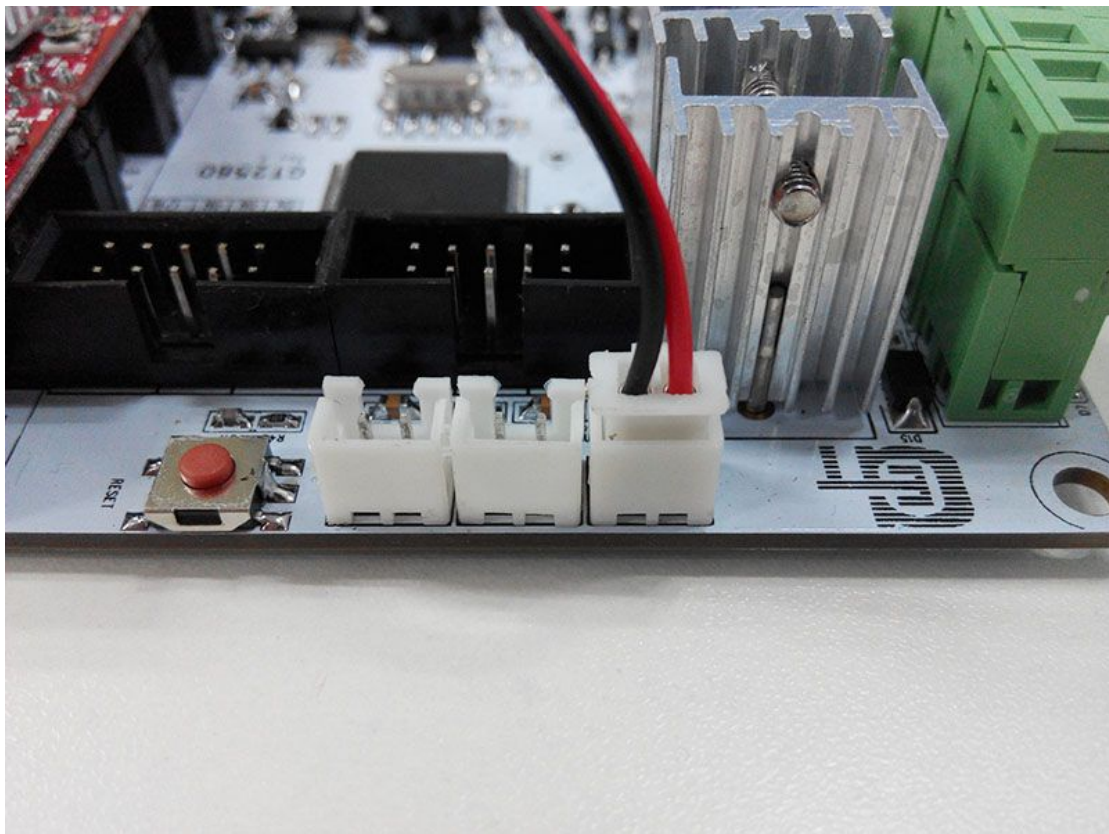

3) Connect wires for thermistor of extruder 2. The wires are on hotend 2.

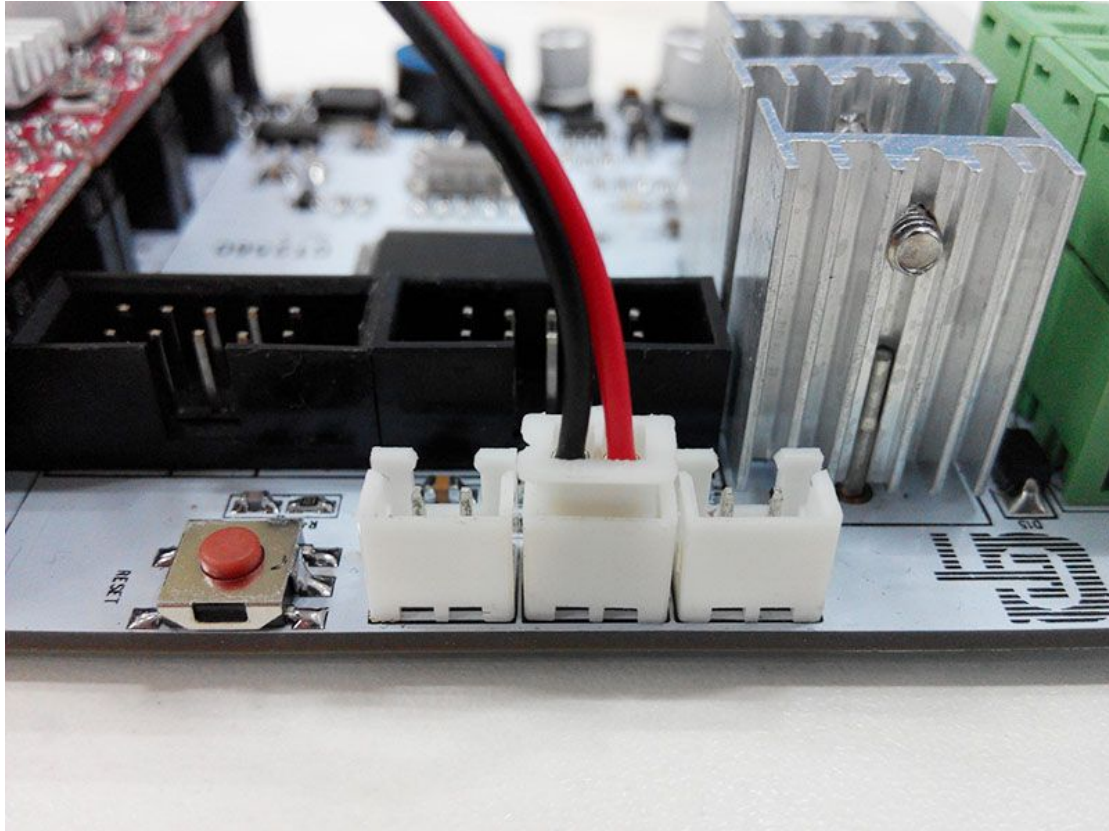

Step5. Connect wires for endstop.

1) Connect wires for endstop of X-axis at X-max.

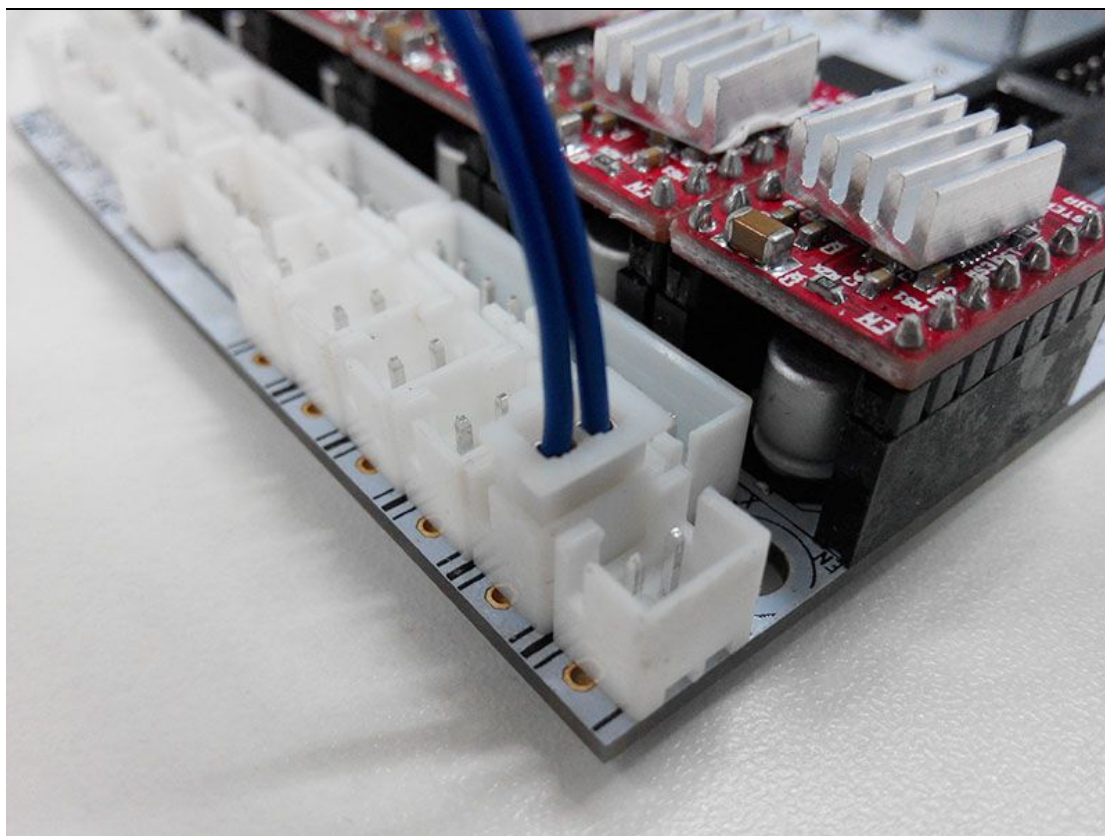

2) Connect wires for endstop of Y-axis at Y-max.

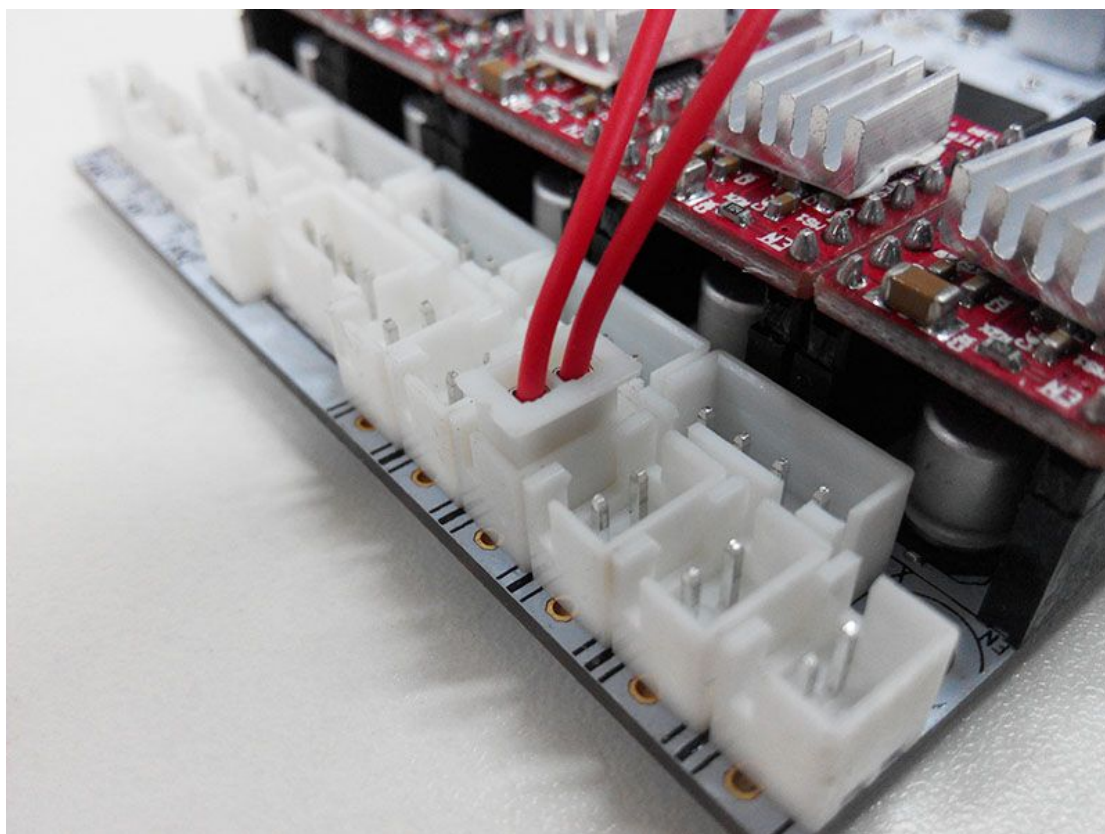

3) Connect wires for endstop of Z-axis at Z-max.

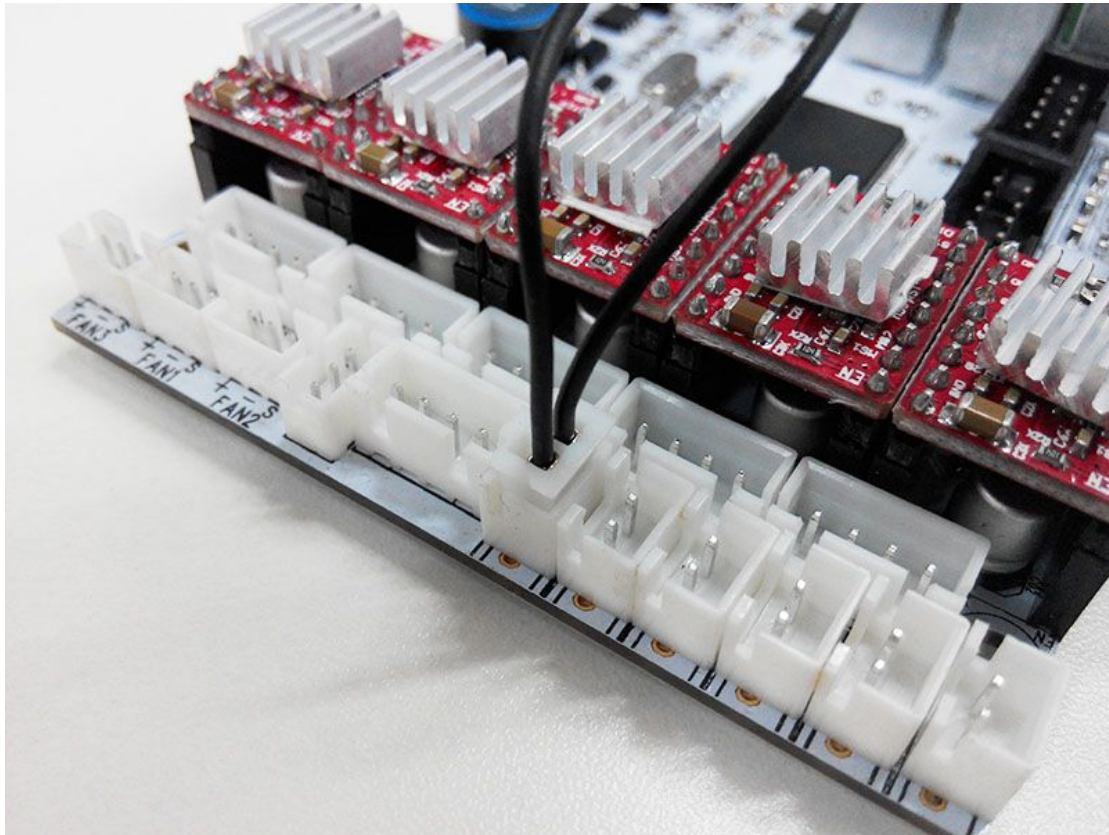

3) Connect wires for endstop of auto-leveling probe at Z-min.

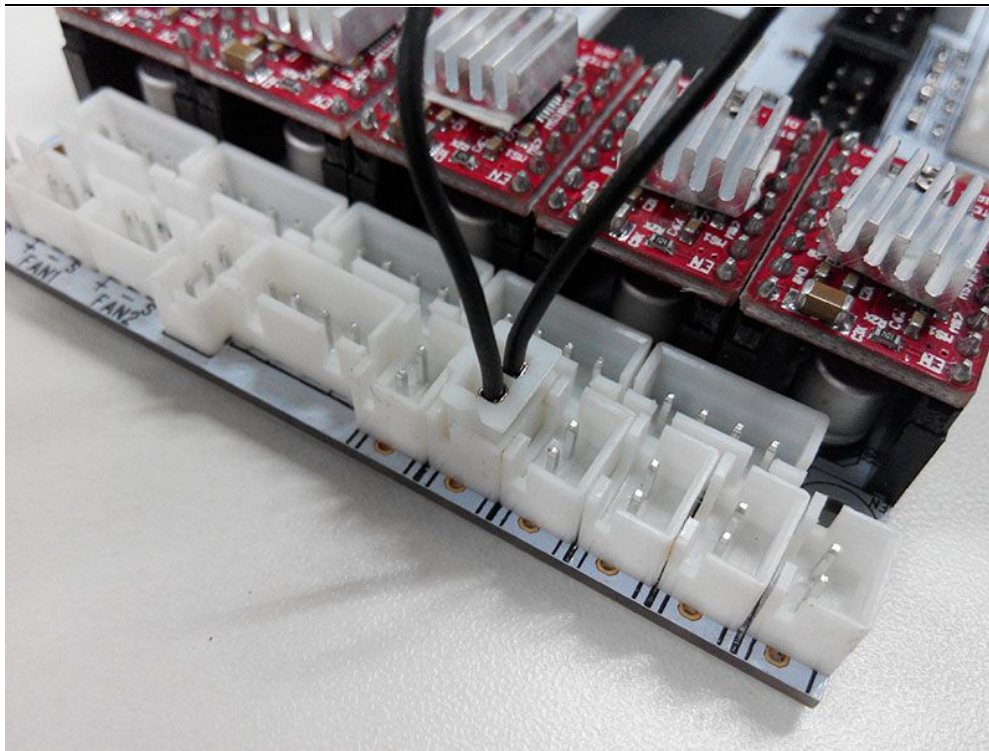

Step6. Connect wires for Fan.

- 1) Connect fan for control board at FAN1.

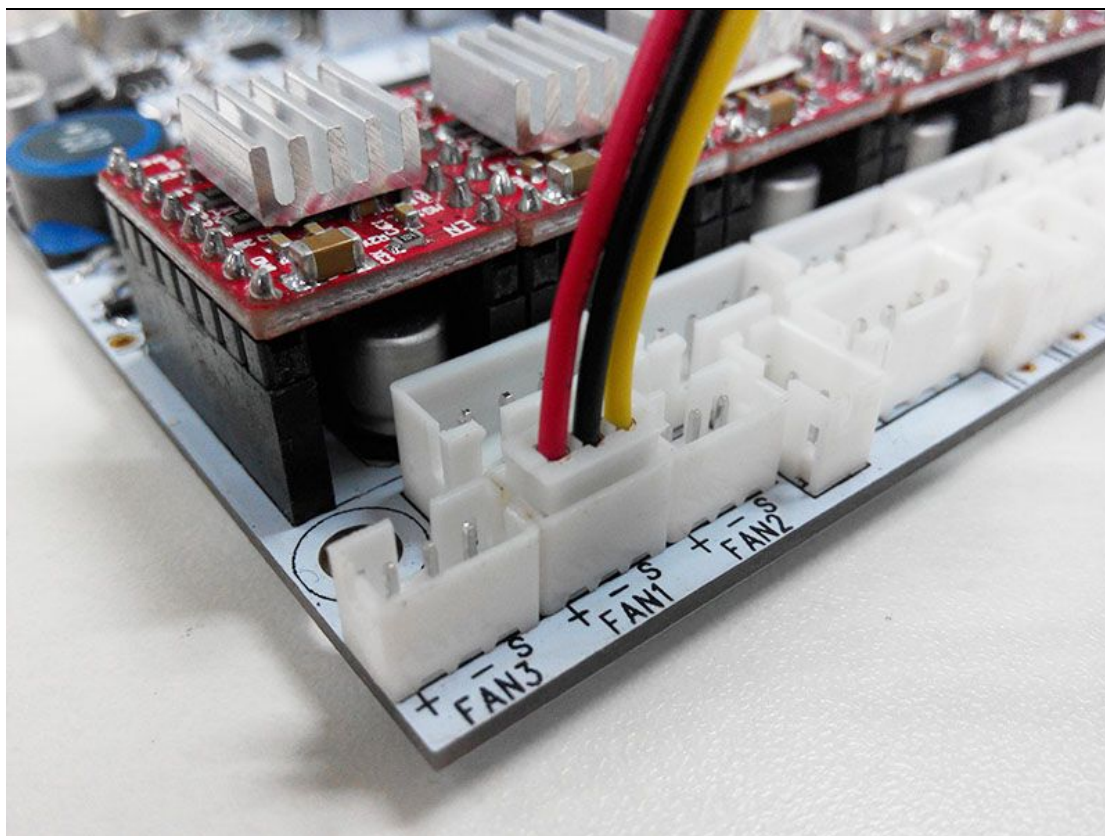

2) Connect fan for extruder at FAN2 and/or FAN3.

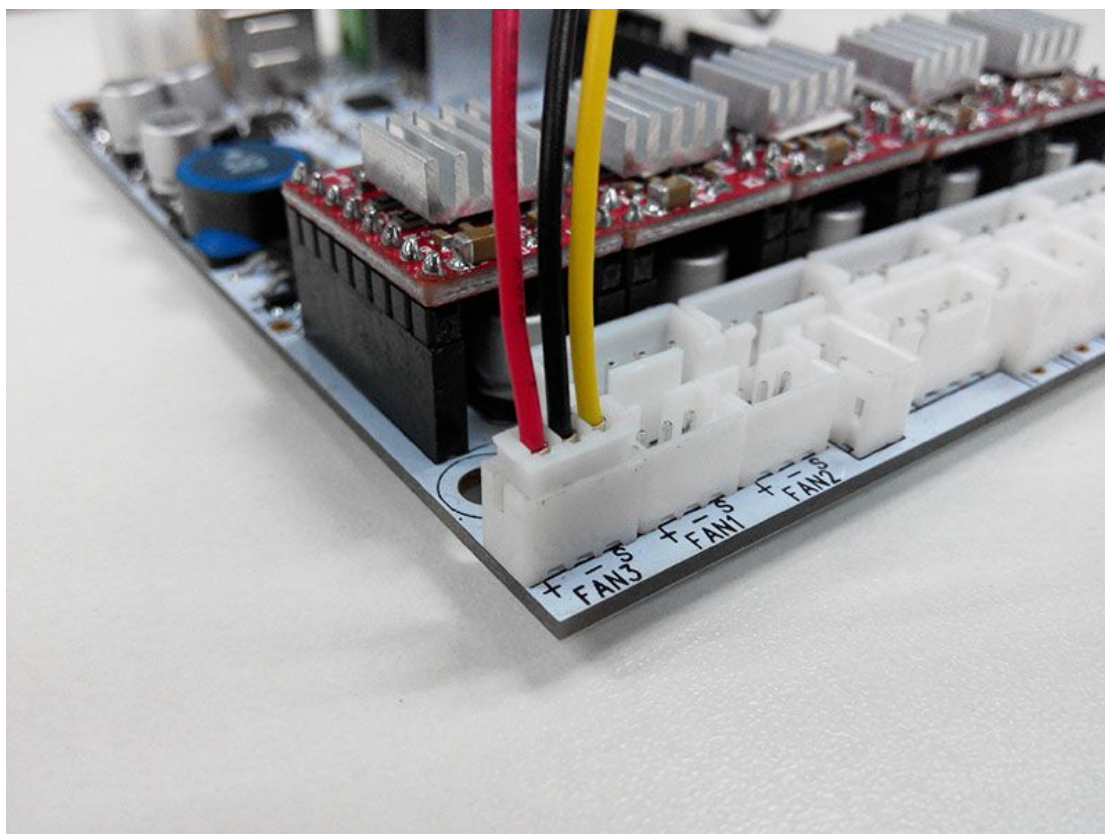

2) Connect fan for hotend at FAN-PWM.

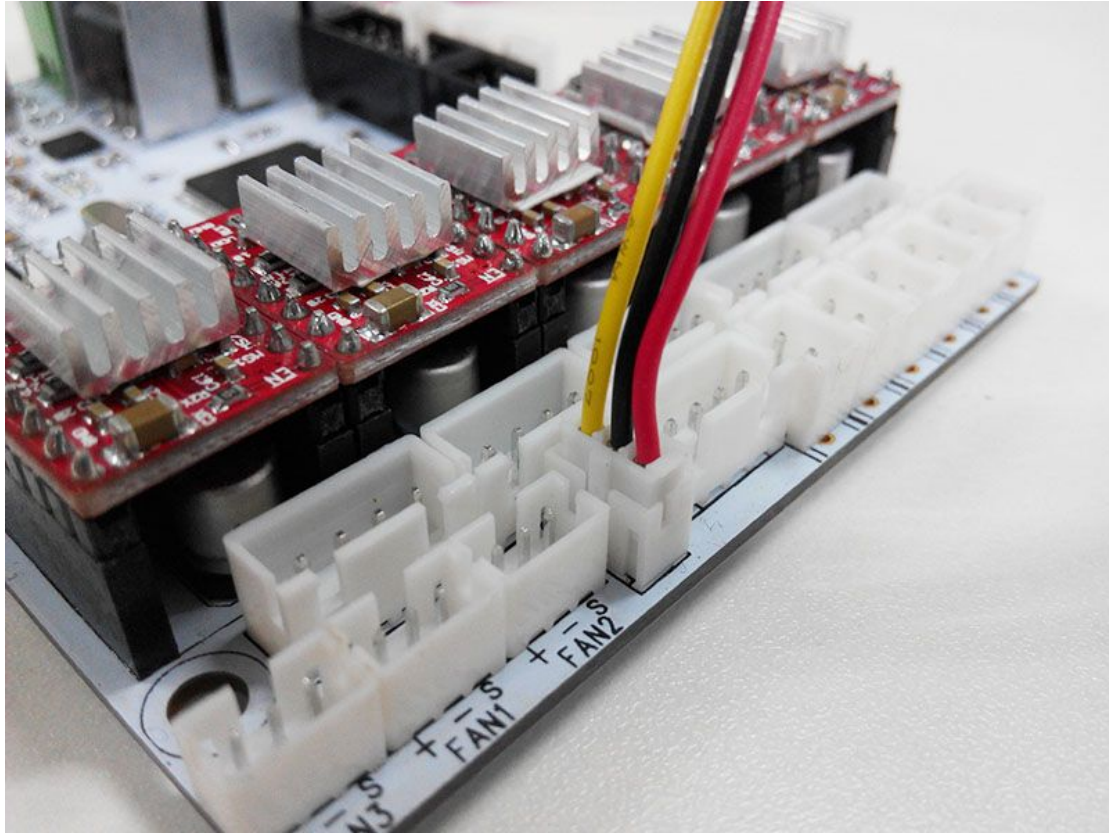

Step7. Connect wires for LCD panel.

There are two cables, one is for LCD encoder, the other is for SD card, do not connect them reversed.

EXP1 to LCD

EXP2 to SD card

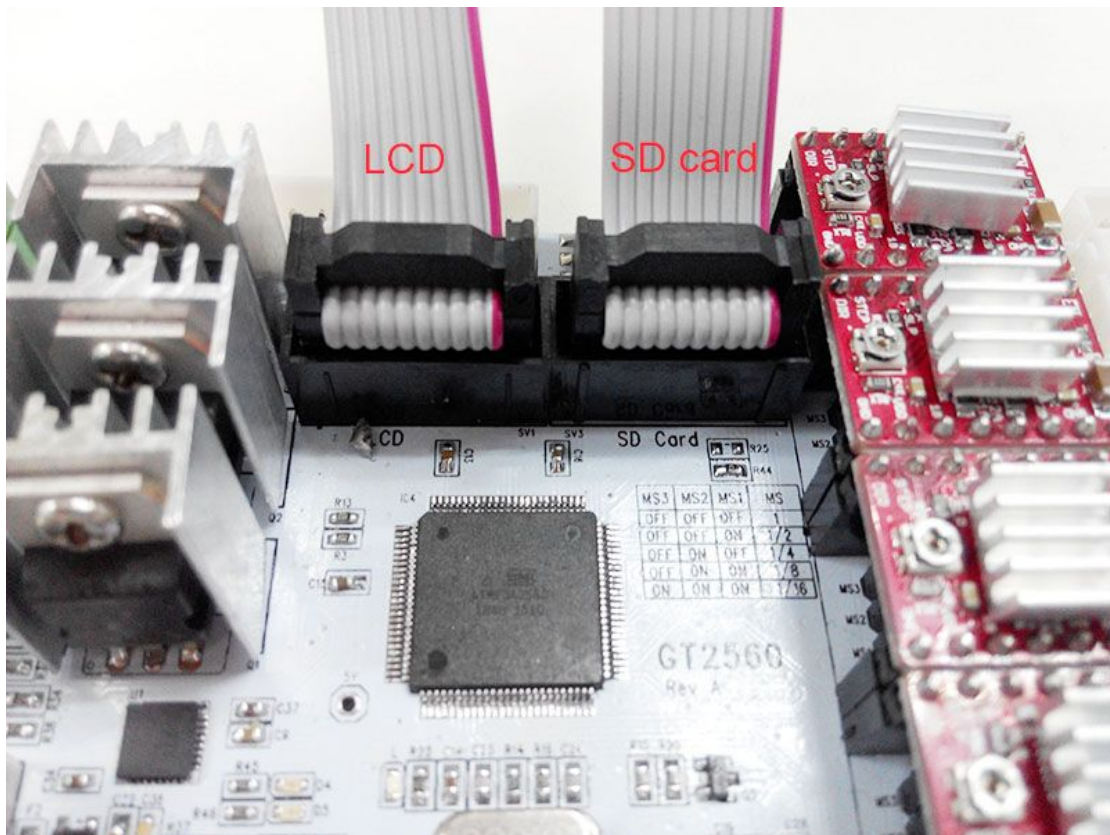
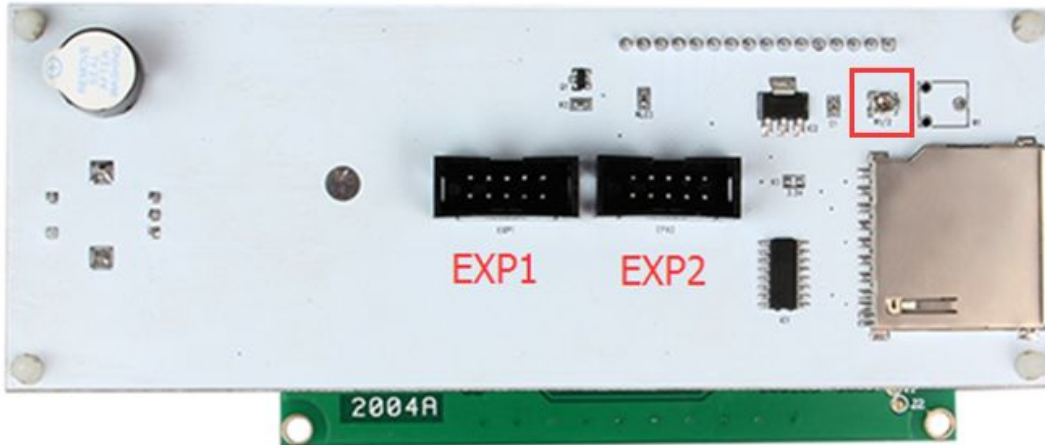

BTW, do you see the small screw above the SD card reader, if the text in of the LCD phases in an out or there is only blocks on the screen, you can adjust this screw to recovery it.

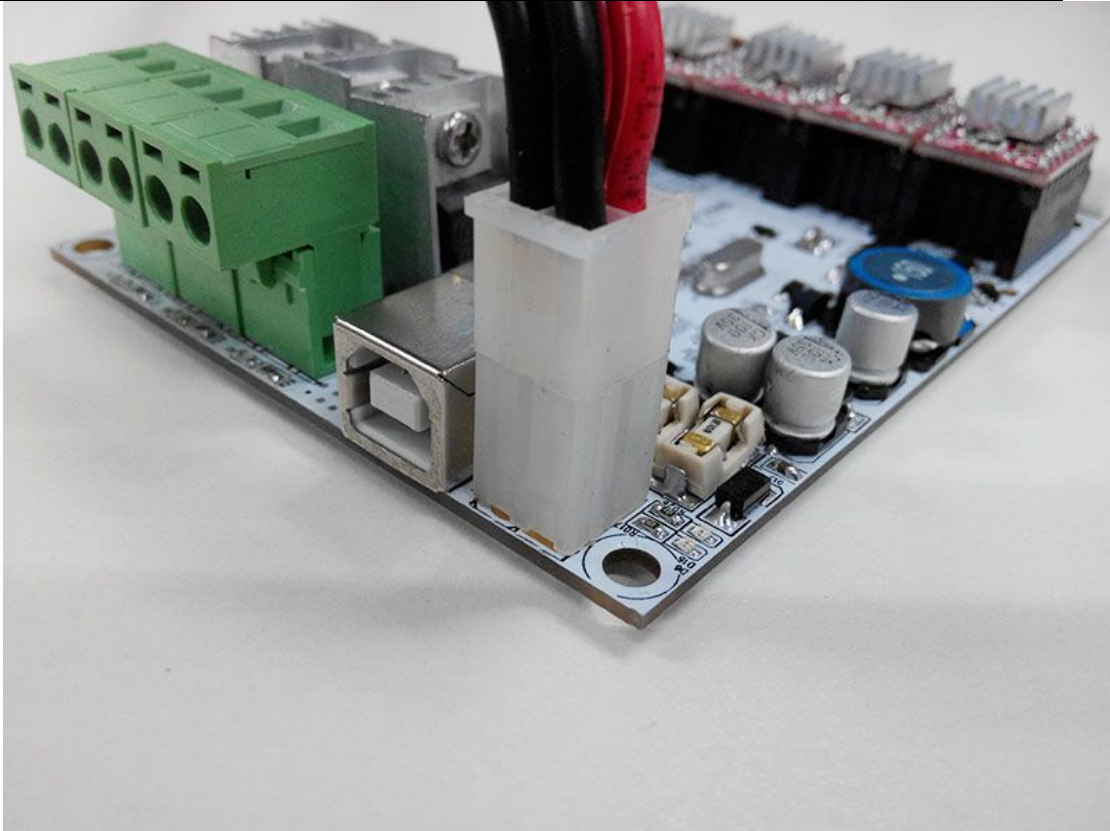

Step8. Connect wires for power input.



Step9.Connect the power cable to the input connector of PSU

Name	Part NO.	Qty	Pic
3D Power cable	NO.59	1	
Power Supply Unit	NO.58	1	

Power Cable	NO.60	1	
-------------	-------	---	---

Connect the wires as shown below:

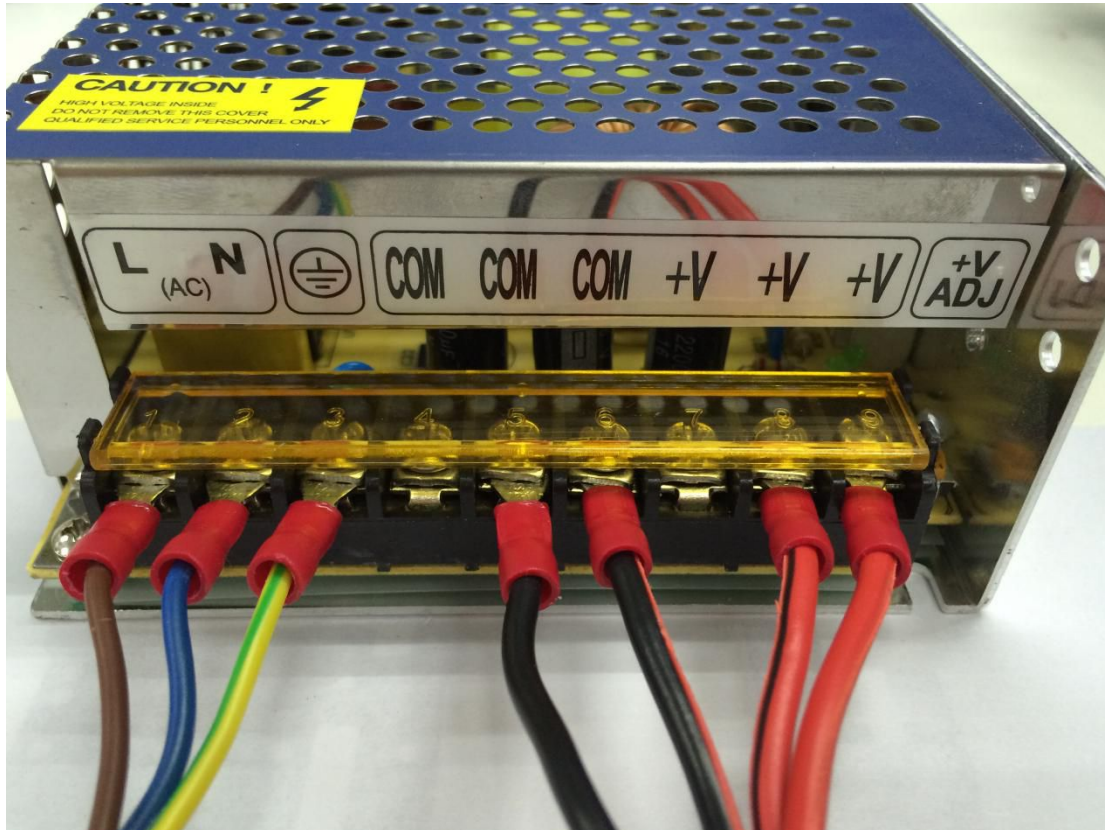

Note the correspondence between the color of wires and the connector.

Brown-----L

Blue -----N

Yellow-----GND

Red ----- + V

Black-----COM

That is all for the wiring of GT2560.

As the PSU is not mounted on the printer, it is kept beside the printer, you should take

good care of it; keep it away from kids and pets.

Videos

13 Tidy out the wires

Use the spiral coil and zip ties to put those wires together.

If you tidy up the wires first before wiring, you are advised to mark each wires or connectors in case you mix them up.

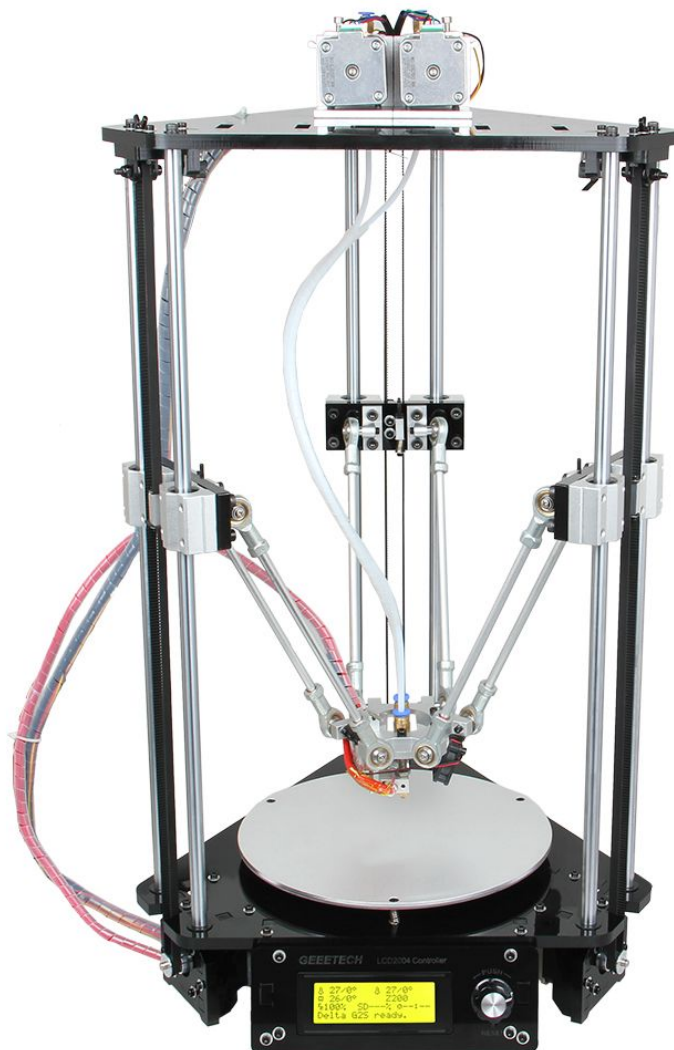

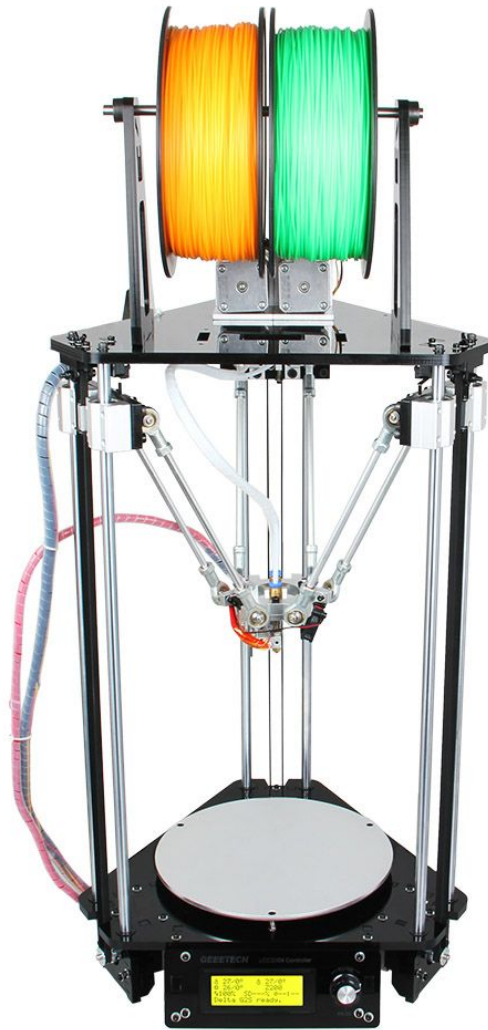

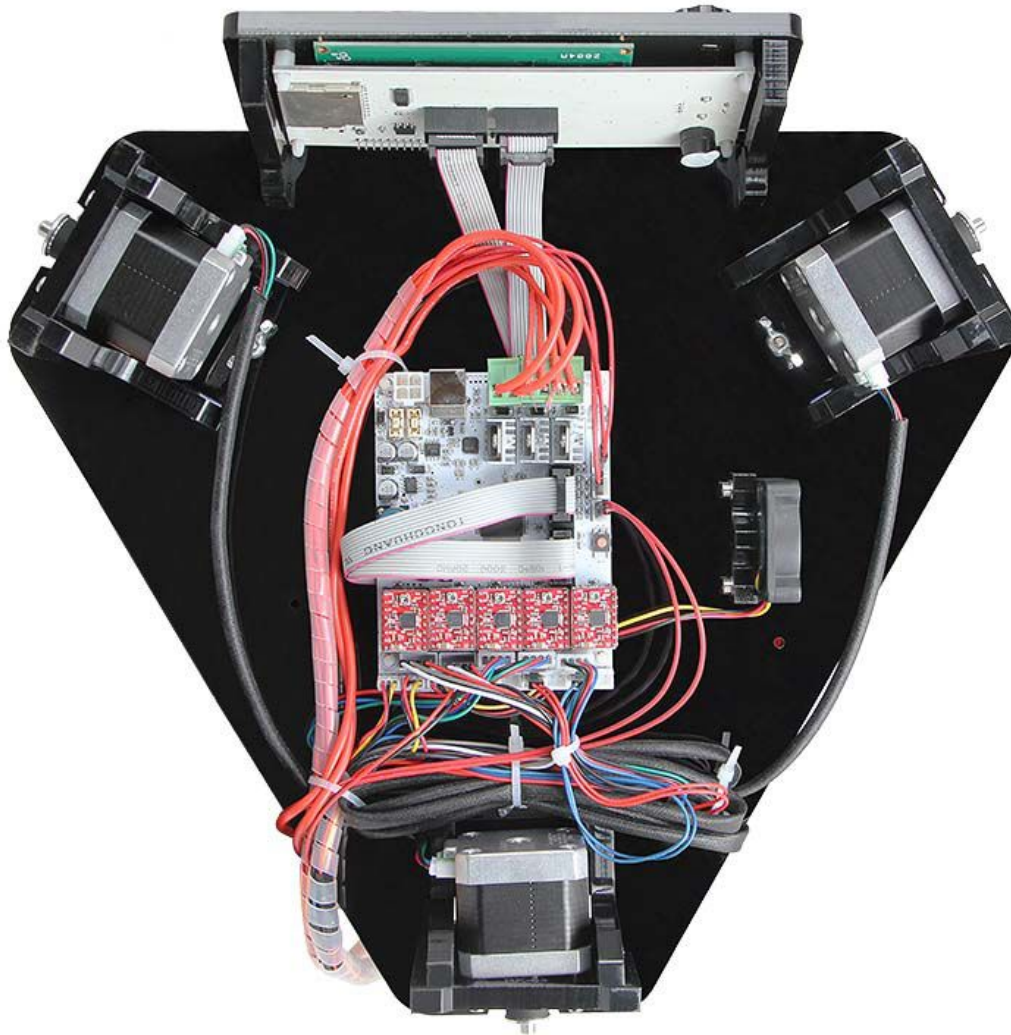

So far, the Rostock mini G2(G2s) has been fully assembled.

14 Tips

Before even attempting the first print it is vital that the printer is correctly calibrated. Skipping or rushing this step will result in frustration and failed prints later, so it is important to take the time to make sure the machine is correctly set up.

Each machine may have its own calibration procedure and this manual will not

attempt to cover all the variations. Instead here is a list of key points that should be addressed.

- Frame is stable and correctly aligned.
- Rods are correctly aligned
- Belts are taut.
- Driving wheel turns smoothly
- Bed is level in relation to the path of the extruder.
- Filament rolls freely from the spool, without causing too much tension on the extruder.
- Current for stepper motors is set to the correct level.
- Wires are correctly connected
- Couplings and pulleys are fixed tightly

Firmware settings are correct including: axis movement speeds and acceleration; temperature control; end-stops; motor directions.

Extruder is calibrated in the firmware with the correct steps per mm of filament.

The point regarding the extruder step rate is vital. Slic3r expects that the machine will accurately produce a set amount of filament when told to do so. Too much will result in blobs and other imperfections in the print, too little will result in gaps and poor inter-layer adhesion.