

Reprap Development Board Interface: ww.reprap.org/wiki/RDB Main interface board: RDB_STP_001_G_DIY_ADJ

OSHW

GLPv3

Power input

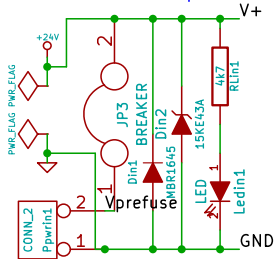

MBR or SPST diode current > fuse, Vbr min = Vin*1.3
15kEA transil unidirectional Vbr min extra rating approx *1.2
For 40-56V inputs use LM317HV, transil 15kE68A, SPST/MBR1660

V.Regulator: adj, logic lvl

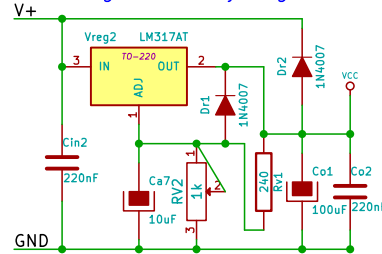

Set Voltage Regulator for logic level voltage.
If development board has its own onboard regulator then match it.
Most regulators 3pin, adj, TO220 are compatible (LM1086), but double check.

Power ends



Holes

- X Hole1
- X Hole2
- X Hole3
- X Hole4
- X Hole5
- X Hole6

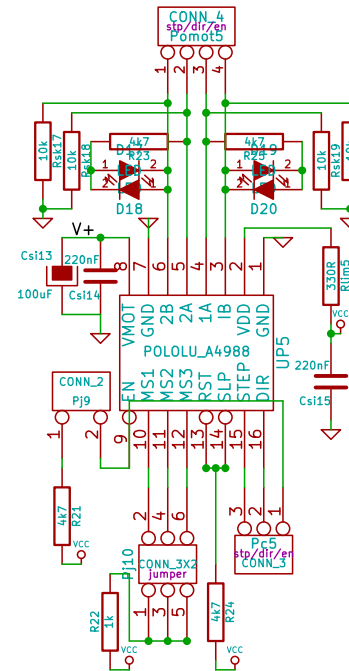
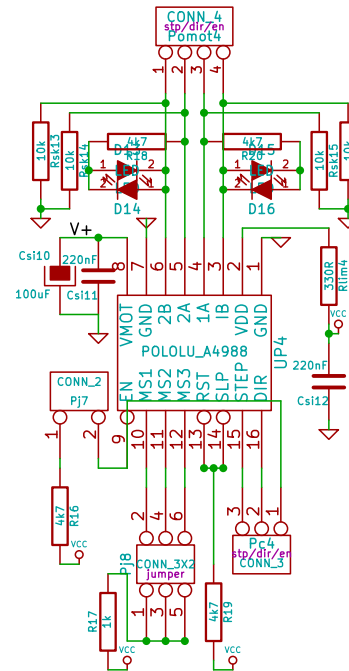
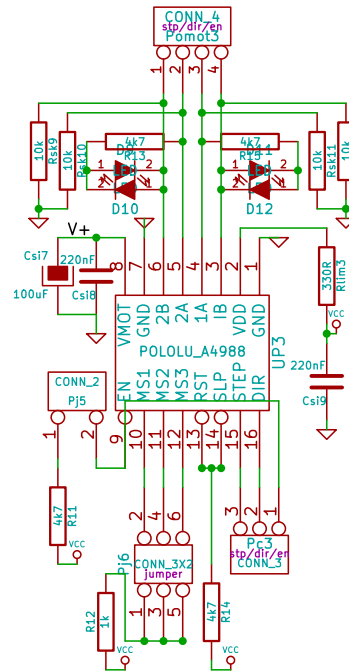
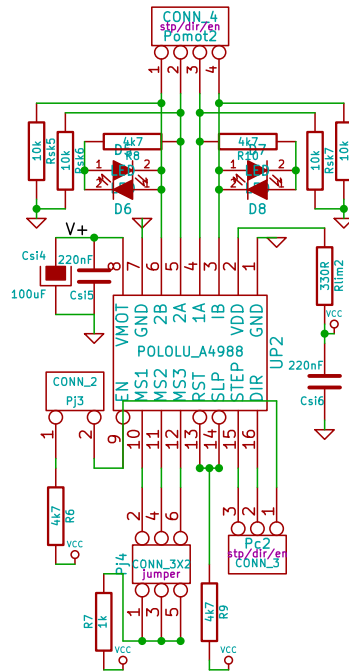
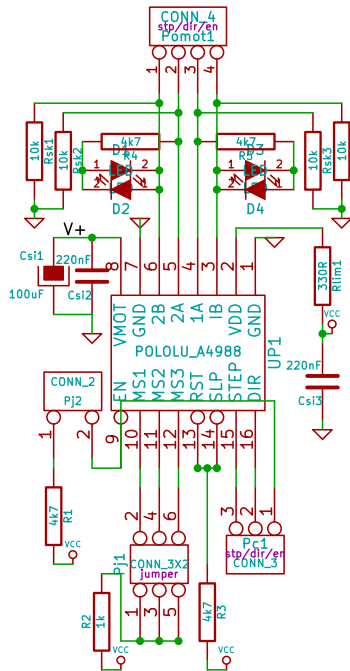

ENABLE: to be low in normal operation, has 100k pulldown onboard (a4988), onchip 100k pulldown (drv8825)
SLEEP: to be high in normal operation & @startup, has 100k pullup onboard (a4988), onchip pulldown 1Mohm (drv8825)
RESET: to be high in normal operation, no default setting onboard (a4988), onchip pulldown 100k (drv8825)
MS: MS1, MS3 pins 100kΩ pulldown, MS2 50kΩ pulldown (a4988), all MS have 100k pulldown for drv8825
DRV8825: to keep faults from pulling sleep low, sleep pullup is 4k7 or less
External schottky diodes: SB540; SR540; 1N5822;

www.reprap.org/RDB

File: RDB_STP_001_G.sch

Sheet: /

Title: RDB_STP_001_G_DIY_ADJ

Size: A4 Date: 10 may 2013

Rev: 001alpha

KiCad E.D.A.

Id: 1/1