

Diagram

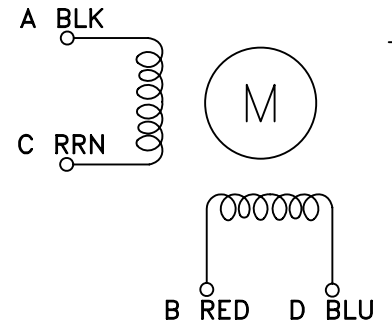

Label:

1.8° Stepper Motor
LDO-42STH47-1684A
120321 LDO MOTORS

Items	Specs	Items	Specs						
Phase Number	2 phases	Step Angle	1.8° ±5%						
Rated Voltage	2.8 VDC	Rated Current	DC 1.68 A / Phase	A	---	New Release	Danny Z	J. B.	03. 21. 12
Resistance(20°C)	1.65±10% Ω / phase	Inductance	2.8±20% mH / Phase	REV	ECN NO	Description	Made by	Approve	Date
Holding Torque	≥ 5.0 Kg-cm	Detent Torque	0.2 Kg-cm REF.				LDO MOTORS CO.,LTD Hybrid Stepper Motor LDO-42STH47-1684A		
Rotate Direction	ABCD CW	MAX Starting PPS	≥2500 PPS						
MAX slewing PPS	≥2500 PPS	Insulation Resistance	≥100 MΩ (DC 500V)						
HI POT	AC600V/1mA/1S	Insulation Class	Class B						
Rotor Inertia	68 g. cm²	Weigth	0.35 Kg REF.	Des.	Check	Appr.	Date	Factory Code	page